

Trust Vauxhall

Protecting the environment

Vauxhall's commitment to the environment is demonstrated by our products' many environmental awards, won both through the use of more recycled materials and by becoming cleaner and more efficient. For information on Vauxhall's efforts to achieve an environmentally sustainable future, see www.vauxhall.co.uk/recycling

Fleet Customer Services

Our dedicated support services for fleet managers includes factory demonstrators, a three-day test drive programme and information on whole life costs, company car taxation and finance. For further information please call **0870 010 0651**.

Buying your car

GMAC offers one of the most comprehensive and competitive ranges of financing plans in the UK. Contact your local Vauxhall retailer for details or call the GMAC customer service centre on **0845 712 3444**.

Sureguard protection

Sureguard Assistance offers the benefits of Vauxhall Assistance for three years from first registration, while Sureguard Warranty also provides a parts and labour warranty for high-mileage or long-term owners. For details contact your local Vauxhall retailer or call **0870 752 7020**.

Specialist Mobility advice

Motability accredited Vauxhall retailers can provide special mobility help and advice. Blue badge holders are entitled to very favourable discounts on new vehicles. Contact your local Motability accredited Vauxhall retailer or **Freefone 0800 731 5267**.

Servicing and maintenance

The best way to maximise the performance and reliability of your Vauxhall is to have all routine servicing and maintenance carried out at one of around 400 Vauxhall retailers. To find your nearest retailer call **0845 600 1500**.

In the event of an accident...

Vauxhall Accident Support helps keep you mobile following an accident. Benefits include scene-of-accident advice, message service, assistance with claims and vehicle recovery. Call **0800 010 304** for a free driver's pack.

Vauxhall Insurance

Available for new and used Vauxhalls, a Vauxhall Insurance policy offers a unique package designed specifically for Vauxhall drivers. For a highly competitive quotation, call **0870 024 0240** or visit our website at www.vauxhall.co.uk

For more information...

For a brochure on any Vauxhall model (up to a maximum of three per caller) or location of your nearest Vauxhall retailer please **Lo-call 0845 600 1500**.

Alternatively, details can be found on our website at www.vauxhall.co.uk

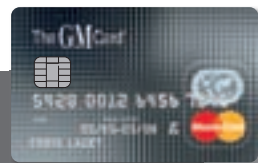

• Save up to £2000* on a new Vauxhall with The GM Card

• 100 Rebate Points worth £100 when you use The GM Card for the first time

• Rebate Point saving is on top of any discount or offer negotiated with the Retailer

• Earn 3 Rebate Points (£3) for every £100 you spend

Typical 14.9% APR variable

To apply call **0845 746 2777** or visit www.gmcard.co.uk

For a copy of this brochure in large print, Braille or on audio CD, please call 01908 553053 (Mon - Fri 09.00 - 17.00), or via our textphone service on 18001 08456 785 785.

The GM Platinum Card is issued by HFC Bank Limited and is available to persons aged 18 years or over and resident in the UK (or 21 and over in the Channel Islands) and is subject to status and conditions. Written quotations are available upon request from The GM Platinum Card PO Box 3615, Birmingham B3 2RJ. The typical APR quoted is the rate for new customers. *Rebate Points are earned on purchases using The GM Platinum Card. Rebate Points are not earned on Balance Transfers or Cash Advances. You earn money off a new Vauxhall/Saab by accumulating Rebate Points under the Rebate Points Programme. Vauxhall Motors Ltd is solely responsible for the operation of the Rebate Points Programme, which is subject to the Rebate Points Programme Rules. You can redeem up to 2500 Rebate Points subject to the Model Line Maximum which will vary in amount in relation to different Vauxhall/Saab vehicle model lines and unlimited Partner Points. Rebate Points and unlimited Partner Points are redeemable as discounts on a new Vauxhall/Saab vehicle and must be redeemed four years from the issue date. Rebate Points may not be redeemed by Motability Contract Hire customers. The GM Card is a trading name and style of both HFC Bank Limited and Vauxhall Motors Ltd. HFC Bank registered in England No. 1117305. Registered Office: North Street, Winkfield, Windsor, Berkshire SL4 4TD is authorised and regulated by the Financial Services Authority. **Member HSBC Group**. HFC Bank Limited is not a member of the same group of companies as Vauxhall Motors Ltd, Saab GB Limited or GMAC (UK) plc. Vauxhall Motors Ltd, Registered Office: Griffin House, Osborne Road, Luton, Bedfordshire LU1 3YT. Registered in England number 135767. - CN6/0987.

Every effort has been made to ensure that the contents of this publication were accurate and up-to-date at the time of going to press (July 2007). Vauxhall vehicles are equipped with components manufactured by various General Motors operating units and outside suppliers. The Company reserves the right to alter specifications and withdraw products from sale without notice. Any such alterations will be notified to Vauxhall retailers at the earliest opportunity, please consult your local retailer for the latest information. The specifications detailed within this brochure are not necessarily applicable to alternative models such as Special Editions. Details of any such models will be contained in specific literature or found on the Vauxhall website. Please note that Vauxhall retailers are not the agents of Vauxhall Motors Limited and are not authorised to bind the Company by any specific or implied undertaking or representation. It is advisable to ensure that your motor insurance policy provides adequate cover for additional fitted options and accessories. As part of Vauxhall's policy of environmental care, this brochure is printed on paper manufactured using Elemental Chlorine Free pulps from specially farmed, sustainable timber resources. All rights reserved. No part of this publication may be reproduced in any form or by any means, without the prior written permission of Vauxhall Motors Limited.

VM0707349 Published August 2007 (BMB/Graymatter) Vauxhall Motors Limited, Luton LU1 3YT



Vectra and Signum

2008 Models Edition 1





VECTRA AND SIGNUM. TAKE CONTROL

Poised, muscular and unmistakably purposeful, Vectra and Signum exude confidence and attitude. Dramatic lines, advanced driving dynamics and the highest levels of interior quality all combine to set high standards of comfort and control. Hatchback, estate or saloon, Vectra is rewarding to drive, whatever the conditions. Equally engaging on the road, Signum presents an exciting blend of space, flexibility and style that's like no other executive hatch.

Vectra and Signum from Vauxhall. Isn't it time you took control?

This brochure covers Vectra Life, Exclusiv, SRi, Design and Elite, and Signum Elegance, Exclusiv, Design and Elite models only. Some of the vehicles shown include options and accessories available at extra cost. And not all of the features described are available on every model. So please check in the Equipment section for further details. From time to time, we also offer alternative Vectra and Signum models such as Special Editions, featured in their own separate literature or found on the Vauxhall website: www.vauxhall.co.uk

Vectra and Signum range	4
Driver features	16
Comfort features	18
Vectra versatility	20
Signum flexibility	22
Engines, transmissions and chassis	24
Safety and security	26
Vectra and Signum line-up	28
Options and accessories	40
Vectra VXR	46
Colours and trims	50
Equipment and technical data	54



REFINEMENT
AND EXCITEMENT
CAN CO-EXIST

“Outstanding refinement; comfortable and enjoyable drive; flexible, clean and frugal engine; classy cabin.”

What Car? – December 2005

VECTRA. A NEW DEFINITION OF REFINEMENT

Vectra's bold and uncompromising lines make a strong statement about the car: significant changes beneath the skin ensure this style is matched with high levels of refinement.

What do we mean by refinement? Smooth, sustainable performance. The ability to conduct a civilised conversation at motorway speeds. The feeling of being in control. Above all, the car is altogether more rewarding to drive, with improved roadholding allied to the highest levels of comfort.



Underlining its reputation for refinement, practicality and roominess, Vectra was named Best Estate Car in the What Car? Car of the Year Awards 2006 and 2007.

"The Vectra can be hustled along a twisty road with total confidence and, yet, even put a smile on your face." *What Car? – November 2005*



SIGNUM. A REDEFINITION OF EXECUTIVE HATCH

With a longer wheelbase that frees up more interior space than even the roomy Vectra hatchback, Signum totally redefines the concept of the executive hatch. More refined and altogether more comfortable, the latest models combine premium saloon quality with the versatility of an estate and the flexibility of an MPV.

Inside, Signum's innovative FlexSpace® concept sets a whole new standard in rear seat passenger comfort. While a state-of-the-art satellite navigation system – fitted as standard on every Signum model – keeps the driver feeling every bit as relaxed as those sitting behind.

"... motorway journeys were impressively quiet, with road and wind noise kept to a minimum. The long sixth gear also ensures that the Signum feels relaxed at 70mph." *Auto Express – 19 October 2005*





ENJOY THE FEELING OF BEING IN CONTROL

"Now beats the rest for refinement, ride comfort,
handling and interior quality..." *What Car?* - November 2005



VECTRA: RELAX IN FULLY EMBRACING COMFORT

"Settle into the tremendous bucket seats (long a Vauxhall strength), start the 2.2-litre petrol engine we chose first and drive away – and immediately things feel good." *MSN Cars UK*

Estate model illustrated left.



DISCOVER
THE SECRET
OF EFFORTLESS
COMPOSURE

"The Vectra has always been a refined car, but now there's an added pizzazz to its repertoire."

Fleet News - 1 September 2005



Enjoy the feeling of being in control

“The cabin is equally accommodating... helping people of all shapes and sizes to get comfortable.” *What Car?* – March 2007

▶ **Multi-function control pad.** Located on the driver's door armrest, this brings together the switches for the electric windows, central door locking and door mirrors in one convenient location.



◀ **Adjustable steering column.** A steering wheel adjustable for reach and rake, backed by a high level of seating adjustment on all models, makes it easy for drivers of all shapes and sizes to achieve the ideal driving position.

Multi-adjustable seats. All models feature eight-way adjustment of the driver's seat (reach, rake, height and tilt) plus lumbar adjustment; eight-way adjustment extends to the front passenger's seat on Design and Elite models.



▲ **Satellite navigation.** Uses the international network of GPS (Global Positioning System) satellites linked to a CD-ROM-based mapping system to guide you to wherever you want to go, anywhere in mainland Britain. A Traffic Message Channel (TMC) function can supply an alternative route when traffic conditions demand, using information received via a dedicated radio frequency. You can even plan your route to avoid motorways! The technology is standard on Vectra Elite and right across the Signum line-up. A range of Vectra Nav models – Life, Exclusiv, Design and SRi – is now available featuring satellite navigation as standard at an attractive price.



◀ **Foldable door mirrors.** Every Vectra and Signum model comes with twin electrically adjustable door mirrors, which are also heated (with an automatic timed cut-off) for fast demisting on wintry mornings. They're foldable, too, helping avoid bumps and scrapes in tight parking situations.

Multi-function display. The centrally positioned, five-inch monochromatic screen displays the time, outside temperature, date and audio information, plus an ice warning. The same display is used for the check control warning functions and trip computer.



▲ **Cruise control.** The easy-to-use, tap-up/tap-down cruise control, is standard on all Vectra and Signum models. It allows you to maintain a steady speed without keeping your foot on the throttle. So it's more comfortable on long journeys and easier to keep to speed limits too.

▼ **Front and rear parking distance sensors.** This optional system helps safeguard your car. Sensors provide an audible warning when an object is sensed in front of or behind the vehicle.





Electronic Climate Control (ECC). Electronic Climate Control (ECC) lets you choose a different temperature from your fellow front passenger – and can even compensate for the effects of sunlight falling on one side of the car.

Sensing features. Headlights that switch on automatically when it gets dark. Wipers that swing into action the moment they sense rain on the windscreen. A rear-view mirror that 'dips' when it detects glare from the car behind. All of these features are standard on Design and Elite models.



Adjustable front seat centre armrest. Another standard feature that combines comfort and practicality for front seat passengers, the adjustable centre armrest has two-stage storage. There's a shallow tray – ideal for your mobile phone and loose change – plus a deeper compartment below.

Air conditioning and automatic air conditioning. Air conditioning means plenty of chilled air on hot days and quicker demisting on damp days – plus a safer, fresher travelling environment all year round. Vectra Design models fitted with the latest automatic air conditioning system offer many of the benefits of ECC – including maintenance of a constant temperature and a built-in sunlight sensor – but with air distribution (windscreen, footwell etc) controlled manually and no central display.



DAB/MP3/Bluetooth® phone technology. Both Vectra and Signum feature high-tech audio systems that put you in full control of the listening environment with features including DAB digital radio, CD autochanger and an advanced MP3 format stereo radio/CD player. The CD 70 audio unit also features an auxiliary-in socket so you can play tracks direct from your personal MP3 player. Integrated mobile phone* technology is also available featuring voice activation and Bluetooth® wireless connectivity. You'll find all the details on page 65 of the Equipment section.

*Please refer to the Vauxhall Car and Accessory Price Guide for a list of phone-specific cradles.

Electrically operated slide/tilt glass sunroof. A lighter cabin, extra fresh air when you need it – plus a preset function that lets you dial in your preferred setting.



Appreciate the high levels of equipment

“Better in all key areas; looks, driving and costs.” *FleetWeek – 31 August 2005*

Vectra. Explore the benefits of flexible space

"... headroom is generous, and there's no arguing with the 500-litre boot."
Auto Express - 7 October 2005



Power tailgate. The estate tailgate can be opened and closed automatically using either the remote control key fob or a button located on the inner tailgate and may be stopped in any position. An obstruction-sensing safety mechanism helps prevent accidents when closing the tailgate.



Load-restraining net. Handily concealed in its own spring-loaded cartridge when not in use, the estate's vertical load-restraining net can be fixed either behind the rear seat or directly behind the front seats when the rear seat is folded down. This helps prevent luggage from being thrown forward into the passenger area during transit.



Underfloor storage. Vectra Estate utilises every spare inch of space, with an underfloor storage area that's perfect for carrying items out of sight and away from the luggage area.

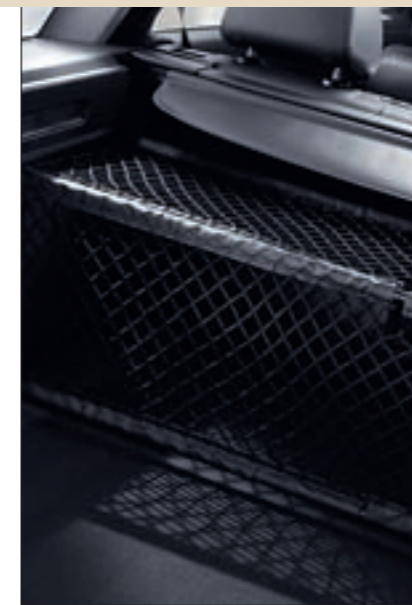

FlexOrganiser® Pack. Consisting of a 3D storage net, side net pocket and four side rail hooks the FlexOrganiser® Pack creates easy, secure and clearly defined storage compartments within the Vectra Estate luggage area, using rails built into the side panels and a flexible arrangement of nets and dividers.

Split-folding rear seat back. All Vectra models feature a 60/40 split-folding rear seat back with folding centre armrest and load-through facility (ideal for longer items of luggage). Both parts of the seat can be folded down in one movement, without removing the head restraints.



Integrated roof rails. Full-length, slimline roof rails accentuate the Vectra estate model's extended roofline as well as providing a practical mounting point for roof carrier accessories such as bicycle carriers and roof boxes.



Generous luggage area. Hatchback and saloon models offer from 500 to 1050 litres of luggage space; the estate is even more impressive with a class-leading 1850 litres. With the rear seat folded the estate (illustrated above) also provides a little over two metres of load floor length – a massive figure by any standards. Full details of the Vectra's loadspace dimensions and luggage capacities can be found on page 71.



Vectra versatility



◀ **Extended wheelbase.** Signum's extended wheelbase – relative to Vectra hatchback and saloon models – helps create a more roomy passenger environment, particularly in the rear. Allied to the car's finely adjustable – and reclinable – FlexSpace® seats, it gives the car a quality that is unique in the marketplace. In addition, full-length, slimline roof rails on Exclusiv and Elite models accentuate the car's extended roofline as well as providing a practical mounting point for roof carrier accessories such as bicycle carriers and roof boxes. The roof rails are also available as an option on Elegance and Design models.

Thanks to its innate roominess and the innovative FlexSpace® rear seating concept, Signum can be transformed in seconds from a plush executive express featuring two fully contoured rear seats with an additional centre rear seat – ideal for that occasional fifth passenger – into a capacious and refreshingly versatile travelling environment, perfectly equipped to accommodate the differing demands of work, family and friends.



◀ ▶ **Individual rear seats.** Slide the two fully contoured individual rear seats back and forth, independently of one another, to achieve the perfect mix of legroom and storage space. There's also a fold-down rear centre armrest.



◀ ▶ **FlexSpace® seating.** With FlexSpace®, you can adjust the rear seat backs to create more room in the luggage compartment... or recline them individually, providing front seat-style comfort. The wide centre armrest provides generous elbow room for two; there's even a built-in console with twin drinks holders! Full details of the Signum's loadspace dimensions and luggage capacities can be found on page 71.



▼ **40/20/40 split rear seat.** Adding to Signum's versatility, the rear seat is split 40/20/40 to accommodate the desired blend of passengers and luggage. Further explanation can be found in the Technical data section on page 74.



▲ **Generous load area.** Fold the rear seat back forward – in a simple, one-handed movement – and you create a massive, flat, 1410 litre load area.



Signum. Adjust your space to suit your mood

"The car is at its best in the rear. Two sumptuous individual chairs provide a limousine feel with exceptional legroom, and are easily folded to create a huge load area." *Auto Express – 5 October 2005*

Experience genuine performance with control

“Vauxhall has made a fantastic job of updating the Vectra. It has managed to retain the superlative refinement and cossetting ride... yet sharpen the drive to the extent that it’s now one of the most rewarding cars in this class. The 2.2i engine is a joy.” *What Car? – November 2005*



◀ **Chassis tuned to UK roads.** The UK’s unique road surfaces present a special challenge to chassis engineers. That’s why so much care has been taken tuning the cars’ chassis to our less-than-perfect surfaces. Specific improvements include revised front anti-roll bars and bushes, revised rear suspension bushes and attendant revisions to springs and dampers. There is also a stiffer ‘handling’ bush in the front suspension to enhance the responsiveness of the steering and specific power assistance characteristics for individual models. The process has been so successful that it has become a fundamental part of all future Vauxhall development programmes.

▶ **Active Select.** The optional five- and six-speed automatic transmissions feature an Active Select facility, which enables drivers to switch from automatic to manual sequential mode using a second transmission gate.



▶ **Advanced diesel line-up.** Both the 120PS 1.9CDTi and 150PS 1.9CDTi 16v common rail diesel engines offer strong performance allied to smooth power delivery and rigorous emissions control; the 16-valve 150PS version is particularly powerful for an engine in this class. And the 3.0CDTi V6 24v engine boosts power even further, making 184PS available to Vectra and Signum drivers.



2.2i 16v direct petrol engine. A high-tech, all-aluminium unit with dual balancer shafts for outstanding smoothness and refinement. The direct injection system increases both power and torque while improving fuel consumption and CO₂ emissions. A six-speed manual gearbox is standard.



▶ **Interactive Driving System-Plus (IDS-Plus).** IDS-plus delivers the ultimate in driver control. Continuous Damping Control (CDC) senses changes in the vehicle dynamics and automatically adjusts the damper rates – in real time – producing greater comfort, more confident cornering behaviour and sharper handling, with reduced body roll. The Sport switch function allows instant switching to a sharper throttle and more responsive steering – and back again – to suit your mood. Further explanation can be found in the Technical data section on page 75.

1.8i 16v petrol engine with Variable Valve Timing. Combining more power and lower fuel consumption, the 140PS 1.8i 16v VVT engine employs Double Continuous Variable Cam Phasing (DCVCP) to provide most of the available torque across a wide rev band.

2.8 litre Turbo engine. Developing 250PS, the 2.8i V6 24v Turbo petrol engine features a twin-scroll turbocharger for rapid response at lower revs and smooth, even, torque distribution. Available with Vectra and Signum Elite six-speed automatic models and Signum Design with manual gearbox.



▶ Remote control alarm system. Ultrasonic security alarm system features forced entry detection, along with tilt, movement and rear glass breakage sensors, plus a power siren complete with its own power supply.



▶ Additional security. Every Vectra and Signum model is packed with security features, including central deadlocking and an engine immobiliser. Hatchback and estate models also feature a luggage compartment cover to hide valuables from prying eyes.



Anti-lock Braking System (ABS). The system has been shown to help reduce stopping distances, particularly on slippery surfaces. By preventing the wheels from locking up, it also allows you to retain control of the steering during emergency braking.



Active-safety front seat head restraints. Activated by the weight of the occupant's body being forced back into the seat, the restraint moves forwards and upright in the event of a rear impact, helping to reduce whiplash injuries.

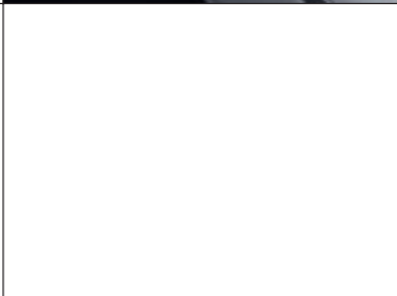

Electronic Brakeforce Distribution (EBD). Works in conjunction with the ABS system to distribute the applied braking force between the wheels most able to use it. This allows the car to brake in a stable manner, whatever load you're carrying.

▶ Adaptive Forward Lighting (AFL). This advanced bi-xenon lighting system ensures the headlight beams are always aimed in the direction you're about to go – and not necessarily the direction the front of the car is already pointing in! As *Autocar* magazine put it in a test report: 'AFL is easy to get used to and hugely improves visibility for night driving.' Further explanation can be found in the Technical data section on page 75.

ISOFIX child seat restraint system. This rigid anchoring mechanism, fitted to the outer rear seats, virtually eliminates the dangers that can result from improper installation, particularly when used with a Vauxhall accessory ISOFIX child seat.



Cornering Brake Control (CBC). Makes the car easier to control in extreme situations, especially when braking sharply on a bend. Particularly effective when carrying out emergency manoeuvres. Further explanation can be found in the Technical data section on page 74.

Emergency Brake Assist (EBA). Detects the urgency with which the brake pedal is pressed and rapidly increases the pressure to the maximum the system can provide, shortening stopping distances. Further explanation can be found in the Technical data section on page 74.

▶ Six airbags. All models come with driver's and front passenger's airbags along with front seat side-impact and full-size curtain airbags.

Electronic Stability Programme (ESP-Plus). Senses when the vehicle is about to slide on a bend and applies braking on up to three wheels, correcting the slide and helping you regain control more rapidly. The system also incorporates traction control. Further explanation can be found in the Technical data section on page 74.

Feel safe and protected at all times

"The car is now a more complete package." *The Sun* – September 2005



VECTRA AND SIGNUM

Vectra and Signum. Two great model ranges tied to a single concept: to give drivers the very best in style, driving refinement and choice. With a mix of hatchback, estate, saloon and executive hatch body styles – backed by a wide selection of engines and trim levels (five for Vectra, four for Signum) it's easy to identify the Vectra or Signum model that is best suited to your needs.

The following pages provide a handy overview of each particular model, broken down by body style, engine availability and equipment highlights; the Equipment and Technical Data section provides the fuller picture.

LIFE

Hatchback | Saloon | Estate

Standard features include:

- Air conditioning
- Driver's and front passenger's airbags
- Front seat side-impact airbags
- Full-size curtain airbags
- Anti-lock braking system
- Eight-way adjustable driver's seat
- Active-safety front seat head restraints
- Steering column adjustable for reach and rake
- Remote control security alarm
- Remote control central deadlocking
- CD 30 stereo radio/CD player
- Steering wheel mounted audio controls
- Cruise control
- Electrically operated front windows
- Electrically adjustable/heated door mirrors
- Chrome-effect interior door handles
- Door-to-door illumination
- Adjustable front centre armrest with storage facility
- Foldable door mirrors
- Interior pollen filter

Engine availability and insurance groups (ABI)

1.8i 16v VVT	9E
1.9CDTi (120PS)	10E
1.9CDTi 16v (150PS)	10E



- Life Nav models feature:**
- CD 70 satellite navigation system with graphic display



Sat Nav

EXCLUSIV

Hatchback | Estate

Standard features include:

- Driver's and front passenger's airbags
- Front seat side-impact airbags
- Full-size curtain airbags
- Eight-way adjustable driver's seat
- Active-safety front seat head restraints
- Remote control security alarm
- Remote control central deadlocking
- CD 30 stereo radio/CD player
- Electrically operated front windows
- Electrically adjustable/heated door mirrors

Additional features over and above Life models:

- Charcoal metallic/aluminium-effect inserts on facia and doors
- Front map reading lights
- Two rear reading lights
- Illuminated vanity mirrors
- Rear seat drinks holders
- 16-inch Structure wheels with 215/55 R 16 ultra-low profile tyres
- Chrome-effect window trim
- Body-colour door handles
- Body-colour sports front air dam
- Two-tone horn

Engine availability and insurance groups (ABI)

1.8i 16v VVT	9E
1.9CDTi (120PS)	10E
1.9CDTi 16v (150PS)	10E

Two-coat metallic paint, optional at extra cost.



- Exclusiv Nav models feature:**
- CD 70 satellite navigation system with graphic display



Sat Nav

Optional Exclusiv Plus Pack includes:

- 17-inch alloy wheels with locking wheel bolts and 215/50 R 17 ultra-low profile tyres
- CDC 40 stereo radio with DAB/integral six-disc CD autochanger with MP3 format/graphic information display
- Front fog lights

SRI
Hatchback | Estate

Standard features include:

- Six airbags
- Eight-way adjustable driver's seat
- Steering column adjustable for reach and rake
- Remote control security alarm
- Remote control central deadlocking
- Body-colour sports front air dam
- Electrically adjustable/heated door mirrors

Additional features over and above Exclusiv models:

- Lowered and uprated sports suspension
- Trip computer
- Sports instruments
- Three-spoke leather-covered sports steering wheel
- Sports front seats
- Front fog lights
- Leather-covered gear knob (manual)
- 17-inch alloy wheels with 215/50 R17 ultra-low profile tyres
- Visible stainless steel exhaust tailpipe (hatchback only)
- Visible dual branch tailpipes on 2.2i 16v Direct, 2.0i 16v Turbo and 3.0CDTi V6 24v (hatchback only)
- Dark-tinted Solar Protect® glass – excludes windscreen and front door windows (estate only)
- Dark-style headlights and tail lights
- Body-colour rear lip spoiler (hatchback only)

Two-coat metallic paint, optional at extra cost.



Optional SRI Plus Pack* includes:

- 19-inch alloy wheels with 235/35 R19 ultra-low profile tyres
- CDC 40 stereo radio with DAB/integral six-disc CD autochanger with MP3 format/graphic information display

**Not available with Exterior Pack models.*

Engine availability and insurance groups (ABI)

1.8i 16v VVT	10E
2.2i 16v Direct	11E
2.0i 16v Turbo	12E
1.9CDTi (120PS)	11E
1.9CDTi 16v (150PS)	11E
3.0CDTi V6 24v	12E

SRI Nav models feature:

- CD 70 satellite navigation system with colour monitor



Colour Sat Nav

SRI Nav models with Exterior Pack (illustrated below) feature:

- 18-inch alloy wheels with 225/45 R18 ultra-low profile tyres
- VXR-style sports front air dam
- Front lower spoiler
- Rear lower skirt
- Rear spoiler
- Side sills
- VXR-style three-spoke leather-covered sports steering wheel
- VXR-style leather-covered gear knob

Model illustrated features Exterior Pack and two-coat metallic paint, optional at extra cost.



DESIGN

Hatchback | Saloon | Estate

Standard features include:

- Six airbags
- Anti-lock braking system
- Eight-way adjustable driver's seat
- Remote control security alarm
- Electrically operated front windows

Additional features over and above Exclusiv models:

- 16-inch alloy wheels with 215/55 R 16 ultra-low profile tyres
- Rain-sensitive windscreen wipers
- Automatic air conditioning
- Electro-chromatic anti-dazzle rear-view mirror
- Automatic lighting control
- Leather-covered steering wheel
- Electrically operated rear windows
- Power tailgate (estate models only)
- Driver information centre incorporating trip computer
- Eight-way adjustable front passenger's seat
- CDC 40 stereo radio with DAB/integral six-disc CD autochanger with MP3 format/graphic information display
- Front fog lights

Engine availability and insurance groups (ABI)

1.8i 16v VVT	10E
2.2i 16v Direct	11E
1.9CDTi (120PS)	11E
1.9CDTi 16v (150PS)	11E

Two-coat pearlescent paint is optional at extra cost.



Design Nav models feature:

- CD 70 satellite navigation system with colour monitor



Colour Sat Nav

ELITE

Hatchback | Estate

Standard features include:

- Six airbags
- Automatic lighting control
- Electro-chromatic anti-dazzle rear-view mirror
- Remote control security alarm
- Electrically operated front and rear windows
- Rain-sensitive windscreen wipers
- Indirect night lighting
- Front fog lights
- Eight-way adjustable driver's and front passenger's seats

Additional features over and above Design models:

- Leather trim
- Electronic Stability Programme (ESP-plus) (V6 models only)
- 17-inch alloy wheels with 215/50 R 17 ultra-low profile tyres
- Electronic climate control
- CD 70 stereo radio/CD player with MP3 format/satellite navigation with colour monitor
- Auxiliary-in socket
- Chrome door handles
- Silver-effect roof rails (estate)

Engine availability and insurance groups (ABI)

2.2i 16v Direct	12E
2.8i V6 24v Turbo automatic	15E
1.9CDTi 16v (150PS)	12E
3.0CDTi V6 24v	13E

5-speed automatic transmission and two-coat pearlescent paint, optional at extra cost.



Optional Elite Plus Pack includes:

- 18-inch alloy wheels with 225/45 R 18 ultra-low profile tyres
- Electrically operated slide/tilt glass sunroof with multi-position pre-set facility and interior blind



Colour Sat Nav

ELEGANCE
Executive Hatch

Standard features include:

- Air conditioning
- Six airbags
- Anti-lock braking system
- Eight-way adjustable driver's seat
- Three-spoke leather-covered steering wheel
- Driver information centre incorporating trip computer
- Cruise control
- Steering column adjustable for reach and rake
- CD 70 stereo radio/CD player with MP3 format/satellite navigation with colour monitor
- Auxiliary-in socket
- Front map reading lights
- Remote control security alarm
- Remote control central deadlocking
- Electrically operated front and rear windows
- Electrically adjustable/heated door mirrors
- Charcoal metallic/aluminium-effect inserts on fascia and doors
- 17-inch alloy wheels with 215/50 R 17 ultra-low profile tyres
- Dark-tinted Solar Protect® glass
- Visible dual branch tailpipes on 2.0i 16v Turbo



Engine availability and insurance groups (ABI)

1.8i 16v VVT	9E
2.2i 16v Direct	10E
2.0i 16v Turbo	12E
1.9CDTi (120PS)	10E
1.9CDTi 16v (150PS)	10E



Colour Sat Nav

EXCLUSIV
Executive Hatch

Standard features include:

- Air conditioning
- Six airbags
- Anti-lock braking system
- Eight-way adjustable driver's seat
- Driver information centre incorporating trip computer
- Steering column adjustable for reach and rake
- Remote control security alarm
- Electrically operated front and rear windows
- Charcoal metallic/aluminium-effect inserts on fascia and doors
- CD 70 stereo radio/CD player with MP3 format/satellite navigation with colour monitor
- Auxiliary-in socket

Additional features over and above Elegance models

- Leather-covered gear knob (manual)
- Lowered and uprated sports suspension
- Front fog lights
- 18-inch alloy wheels with 225/45 R 18 ultra-low profile tyres
- Silver-effect roof rails
- Two-coat metallic or pearlescent paint



Engine availability and insurance groups (ABI)

1.8i 16v VVT	9E
2.2i 16v Direct	10E
1.9CDTi (120PS)	10E
1.9CDTi 16v (150PS)	10E



Colour Sat Nav

DESIGN

Executive Hatch

Standard features include:

- Air conditioning
- Six airbags
- Eight-way adjustable driver's seat
- Trip computer
- Remote control security alarm
- Electrically operated front and rear windows
- 17-inch alloy wheels with 215/50 R17 ultra-low profile tyres
- CD 70 stereo radio/CD player with MP3 format/satellite navigation with colour monitor
- Auxiliary-in socket

Additional features over and above Elegance models:

- Electronic Stability Programme (V6 models only)
- Lowered and uprated sports suspension
- Sports front seats
- Rain-sensitive windscreen wipers
- Automatic lighting control
- Electro-chromatic anti-dazzle rear-view mirror
- Eight-way adjustable front passenger's seat
- Dark-style headlights and tail lights
- Front fog lights
- Indirect night lighting
- Visible stainless steel exhaust tailpipe on 1.9CDTi models
- Visible dual branch tailpipes on 2.2i 16v Direct, 2.0i 16v Turbo and V6 models

Two-coat metallic paint, optional at extra cost.**Engine availability and insurance groups (ABI)**

2.2i 16v Direct	10E
2.0i 16v Turbo	12E
2.8i V6 24v Turbo	15E
1.9CDTi (120PS)	10E
1.9CDTi 16v (150PS)	10E
3.0CDTi V6 24v	12E



Colour Sat Nav

ELITE

Executive Hatch

Standard features include:

- Six airbags
- Anti-lock braking system
- Eight-way adjustable driver's seat
- Leather-covered steering wheel
- Trip computer
- Steering column adjustable for reach and rake
- Remote control security alarm
- Remote control central deadlocking
- Electrically operated front and rear windows
- CD 70 stereo radio/CD player with MP3 format/satellite navigation with colour monitor
- Auxiliary-in socket

Additional features over and above Elegance models

- Electronic Stability Programme (V6 models only)
- Leather seat and door trim
- Eight-way adjustable front passenger's seat
- 17-inch alloy wheels with 215/50 R17 ultra-low profile tyres
- Electronic climate control
- Rain-sensitive windscreen wipers
- Automatic lighting control
- Electro-chromatic anti-dazzle rear-view mirror
- Front fog lights
- Chrome-effect door handles
- Indirect night lighting
- Visible dual branch tailpipes on 2.0i 16v Turbo and V6 models
- Silver-effect roof rails

Two-coat pearlescent paint, optional at extra cost.**Engine availability and insurance groups (ABI)**

2.2i 16v Direct	11E
2.0i 16v Turbo	13E
2.8i V6 24v Turbo automatic	15E
1.9CDTi 16v (150PS)	11E
3.0CDTi V6 24v	13E



Colour Sat Nav

Options and accessories

Vauxhall options and accessories are all about choice – selecting your new car, then personalising it to suit yourself. There's a choice of factory-fitted options and a huge range of retailer-fit accessories. You can also choose styling products from the VXR range as well as auto design specialist Irmischer International. You'll find further information on the following pages or just ask your Vauxhall retailer for more details.



VXR Styling

Inspired by our hugely successful racing team, VXR styling products reflect their experience, knowledge and passion for style and performance. Available on Vectra as factory-fit option packs or accessories fitted by your Vauxhall retailer, the VXR range adds flair, personality and excitement to your car.

◀ ▼ Vectra VXR Styling Pack One*

- Front lower spoiler
- Rear lower skirt (Hatchback/Estate)
- Rear lip spoiler (Hatchback)
- Rear roof spoiler (Estate)
- Side sills

*Factory-fit option pack not available on saloon models. However, individual VXR styling parts are available as retailer-fit accessories. Model illustrated also features optional 19-inch alloy wheels.



Developed in conjunction with auto design specialists Irmischer International, Vectra and Signum styling accessories perfectly complement the vehicle's lines, as well as being manufactured to the same exacting standards as the cars themselves. For availability details of these features, please refer to the Vauxhall Car and Accessory Price Guide.

Model illustrated features Irmischer front lower spoiler, cross hatch grille with aluminium upper and laser-etched 'Irmischer' logo, side sills, chrome-effect door mirror covers, rear roof spoiler and 19-inch GT Star alloy wheels.

Irmischer

▶ **Irmischer alloy wheels.** They're the perfect way to personalise your Vectra and Signum. With a huge range to choose from (style illustrated is Stila), and sizes from 16 to 20 inches, you're sure to find one to suit your style and budget. And don't forget to ask about our accessory wheel locking kits too.





◀ **Mobile phone system with Bluetooth®***. With the optional mobile phone system, your phone interfaces with the audio unit, for full operation via the steering wheel controls and fascia display. Bluetooth® wireless connectivity with voice activation is included. See page 65 for more detailed information.

*Please refer to the Vauxhall Car and Accessory Price Guide for a list of phone-specific cradles.

▼ **Slide/tilt glass sunroof.** The electrically operated slide/tilt glass sunroof features a preset dial function enabling you to choose your preferred setting.

▼ **FlexOrganiser® Pack (Estate only).**

- 3D storage net
- Side net pocket
- Four side rail hooks



Individual options include:

- Electrically operated slide/tilt glass sunroof
- Interactive Driving System-plus with Continuous Damping Control
- Parking distance sensors



Towing Pack (Estate only).

- Retractable tow bar
- Self-levelling rear suspension (not with sports suspension)
- Trailer stability programme
- Electronic Stability Programme (ESP) incorporating traction control



Without AFL.

▶▶ **Adaptive Forward Lighting (AFL).** The optional lighting system swivels the headlight beams up to 15 degrees for improved vision as you turn a corner. Above 65mph, it raises the dipped headlight beam slightly, also to increase safety – returning to normal beam automatically as speed is reduced. See page 75 for more detailed information.

Available individually or in special packs at great prices, Vectra and Signum options can make life better in so many ways. Parking distance sensors, Adaptive Forward Lighting, an electric sunroof – there's a huge range to choose from. Simply make your choice when you order your new car and it'll be fitted at the factory for you. You'll find further information on availability in the Equipment section. Or you can ask your Vauxhall retailer.



With AFL.

Vauxhall accessories are the right choice for your Vectra and Signum. Whatever you're into, there's certain to be a Vauxhall accessory with your name on it; all fitted by trained Vauxhall professionals. We've only featured a small selection of what's available here. The Vauxhall Car Accessory Brochure and Car and Accessory Price Guide give further details. Or check out our website at www.vauxhall-accessories.com



▶ Child seats. Vauxhall offers a range of child seats, ergonomically styled for comfort and safety. The Baby-Safe (for babies from birth to 13kg), and Kid (15-36kgs) seats are fixed with a standard lap and diagonal seatbelt, while the Duo ISOFIX (9-18kg) can also be attached using the ISOFIX child seat restraint fittings, which are standard on the outer rear seats of all Vectra and Signum models. The rigid ISOFIX anchoring mechanism virtually eliminates the dangers of incorrect child seat installation.



▶ Side loading bicycle carrier. The perfect solution for easy loading and unloading, this innovative carrier has a swinging support bar which ensures the bike clears the side and roof of the car. A gas-assisted strut helps take the weight of the bike. Two carriers can be fitted to one base carrier.



▶ Base carrier and roof box. The Vauxhall roof rack system begins with a base carrier, comprising two T-track roof bars which support a wide range of attachments. These include a choice of high capacity roof boxes, each one lockable and easy to fit.



▶ Tow bar and 12N electrics. Tow in confidence with the detachable tow bar available for Vectra and Signum. It won't get in the way when you don't need it. But it's easy to mount when you do. And naturally, it is tested to comply with top European standards. Accessory towing mirrors are also available.

Vauxhall accessory packs bring together a selection of essential accessories at great prices, helping you to protect your car and equipping you for roadside emergencies.

▶ Map net. Ideal for securing all those odds and ends that might clutter up your cabin area, and a perfect place to store your map.



▶ Protection Plus Pack.

- Paint and trim protection
- Velour mats
- Mudflaps



▶ Dog guard with space divider grid* (estate only). The heavy-duty steel dog guard helps keep your pet secure and protects passengers in the event of sudden braking. The space divider grid (sold separately) allows luggage to be stored on one side, and the dog to travel on the other.

*The space divider grid can only be used in conjunction with the dog guard. N.B. Dog guard requires fitting kit (retailer-fit only) if vehicle is not equipped with the optional factory-fit vertical load restraining net.



▶ Protection Pack.

- Velour mats
- Mudflaps
- Cargo liner

▶ Travel Pack.

- First aid kit
- Warning triangle
- Spare bulb kit (not for AFL headlights)
- Fire extinguisher
- Hi-visibility vest



VECTRA VXR

This is extra-sensory stimulation. Cars with soul and power to make you feel alive, electrified and inspired. A range of driver-focused, performance machines for the road, born on the track.





- > Hatchback and estate bodystyles
- > Lowered and uprated VXR sports suspension
- > Twin chrome trapezoidal exhaust tailpipes
- > Recaro sports front seats
- > 18-inch alloy wheels
- > 19-inch alloy wheels with anthracite inner, optional at extra cost (right)



DISCOVER 6.1SEC
0-60MPH

VXR takes the experience, knowledge and passion gained from racing and crystallises it into a range of performance road cars.

For more information on the Vectra VXR please ask your Vauxhall retailer for a copy of the latest VXR range brochure.

"THE VXR REALLY DELIVERS.
IT'S AN EXPLOITABLE, COMPOSED
AND EXCITING CAR TO HANDLE."

EVO - APRIL 2006



Vectra VXR.

Unique VXR body styling... powerful 280PS, 2.8i V6 24v turbo engine... 0-60 in 6.1 seconds (hatchback)... dual-processor Continuous Damping Control. Few other mid-range five-seat hatchbacks, or estates for that matter, have such stunning performance credentials. But then Vectra VXR has never been about following convention. Put simply, it's the best Vectra yet!

Vectra and Signum are available in a range of stylish exterior paint finishes and interior trims, all chosen to complement each other and reflect the individual status of each model. Speak to your Vauxhall retailer about the choices on offer.

Due to the limitations of the printing process the colours reproduced may vary slightly from the actual paint colour or trim material. As a result they should be used as a guide only. Your Vauxhall retailer has a comprehensive display of all our paint samples and trim swatches.

▶ Glacier White – solid



▶ Flame Red – solid



▶ Star Silver – metallic



▶ Silver Lightning – metallic



▶ Metro Blue – metallic



▶ Peacock – pearlescent



▶ Black Sapphire – pearlescent



▶ Panacotta – pearlescent



▶ Pomegranate Red – pearlescent



▶ Ultra Blue – pearlescent



Charcoal Champion

Charcoal Scala

Charcoal Alpha/Morrocana

Charcoal Duke



Charcoal Draht/Leather

Charcoal Leather

Beige Leather

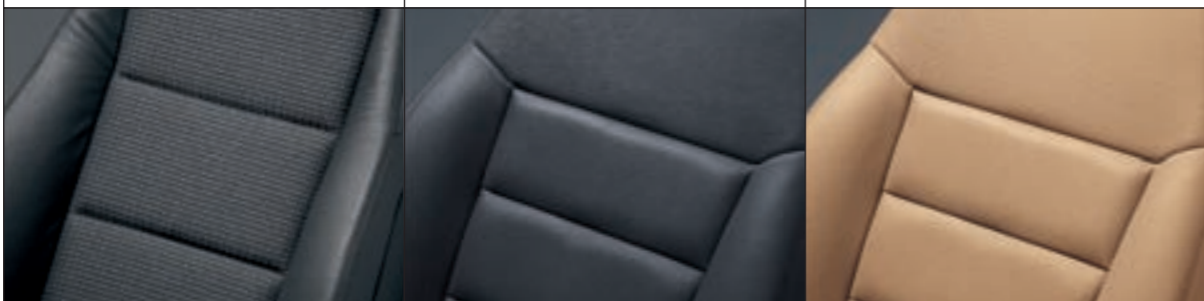

Exterior colours

Model, trim name and trim colour

	Model, trim name and trim colour									
	Life Champion cloth	Exclusiv Scala cloth	Vectra Design Alpha cloth/Morrocana	Elite Leather	SRI Duke cloth	Elegance Scala cloth	Signum		Elite Leather	
							Exclusiv Scala cloth	Design Draht cloth/Leather		
Solid										
Glacier White†	Charcoal	Charcoal	Charcoal	Charcoal or Beige	Charcoal	Charcoal	Charcoal	Charcoal	Charcoal or Beige	
Flame Red	Charcoal	Charcoal	Charcoal	Charcoal or Beige	Charcoal	Charcoal	Charcoal	Charcoal	Charcoal or Beige	
Two-coat metallic*										
Star Silver	Charcoal	Charcoal	Charcoal	Charcoal or Beige	Charcoal	Charcoal	Charcoal	Charcoal	Charcoal or Beige	
Silver Lightning	Charcoal	Charcoal	Charcoal	Charcoal or Beige	Charcoal	Charcoal	Charcoal	Charcoal	Charcoal or Beige	
Metro Blue	Charcoal	Charcoal	Charcoal	Charcoal or Beige	Charcoal	Charcoal	Charcoal	Charcoal	Charcoal or Beige	
Two-coat pearlescent*										
Peacock†	Charcoal	Charcoal	Charcoal	Charcoal or Beige	Charcoal	Charcoal	Charcoal	Charcoal	Charcoal or Beige	
Black Sapphire	Charcoal	Charcoal	Charcoal	Charcoal or Beige	Charcoal	Charcoal	Charcoal	Charcoal	Charcoal or Beige	
Panacotta†	Charcoal	Charcoal	Charcoal	Charcoal or Beige	Charcoal	Charcoal	Charcoal	Charcoal	Charcoal or Beige	
Pomegranate Red†	Charcoal	Charcoal	Charcoal	Charcoal or Beige	Charcoal	Charcoal	Charcoal	Charcoal	Charcoal or Beige	
Ultra Blue	Charcoal	Charcoal	Charcoal	Charcoal or Beige	Charcoal	Charcoal	Charcoal	Charcoal	Charcoal or Beige	

* = Optional at extra cost (standard on Signum Exclusiv models). † = Not available on Exterior Pack models.

Contents

Equipment	
Model availability	54
Safety	55
Interior lighting	
Facia, instruments and controls	
Interior features	56
Heating and ventilation	
Seating and upholstery	57
Rear seating and FlexSpace®	
Exterior and convenience features	58
Mechanical	59
Exterior lighting	
Exterior styling and protection	60
Wheels and tyres	61
Option packs	62
Audio, communication and navigation	64
Technical data	
Petrol engines	66
Diesel engines	
Petrol engine performance, fuel economy and emissions	67
Diesel engine performance, fuel economy and emissions	68
Vauxhall Assistance and warranties, transmissions, suspension, brakes and steering	69
Vectra exterior dimensions	70
Signum exterior dimensions	71
Loadspace dimensions	
Luggage capacities	
Weights and towing data	72
Features explained	74

Model availability

	Vectra						Signum			
	Life	Excl.	Design	Elite	SRi	SRi XP	Eleg.	Excl.	Design	Elite
4-door saloon	■		■							
5-door hatchback	■	■	■	■	■	■				
5-door estate	■	■	■	■	■	■				
5-door executive hatch							■	■	■	■

■ = This model is available with this body style.

Safety

Standard features • Driver's airbag • Front passenger's airbag • Front seat side-impact airbags • Full-size curtain airbags • Energy-absorbing steering column • Pedal release system – Reduces potential injury to the driver's legs and feet during a severe frontal impact • Laminated windscreen • Side-impact protection beams • Integral protective side door padding • Reinforced passenger safety cell • Deformation zones front and rear • Burst-proof door locks and anti-jam door design

• ISOFIX child seat system for outer rear seats (does not include child seat) – Secures ISOFIX child safety seats to the vehicle itself, virtually eliminating the dangers that can result from improper installation • Child-proof locks on rear doors

• Anti-lock Braking System (ABS) • Electronic Brakeforce Distribution (EBD) • Cornering Brake Control (CBC) – see **D1** on page 74 • Emergency Brake Assist (EBA) – Increases brake force applied in emergency braking situations – see **D2** on page 74 • Adaptive Brake Lights (ABL) – If the driver brakes hard enough to activate the ABS function the brake lights flash on and off at a frequency of four times per second, thus warning following vehicles that heavy braking is in progress

• Active-safety front seat head restraints • Height-adjustable head restraints on outer rear seats • Five lap and diagonal inertia-reel seatbelts (height-adjustable front and outer rear) • Pyrotechnic front and outer rear body-lock seatbelt pretensioner system – Tightens the seatbelt during the early stages of a frontal impact • Front seatbelt force limiters – Reduces potential upper body injuries during a frontal impact • Outer rear seatbelt force limiters (excludes Vectra estate) • Anti-submarining ramps in all seats – Help prevent occupants sliding underneath the lap belt during a collision

Additional features	Vectra						Signum			
	Life	Excl.	Design	Elite	SRi	SRi XP	Eleg.	Excl.	Design	Elite
Trailer stability programme (estate)	□	□	□	□	□	□				
Electronic Stability Programme (ESP-plus) incorporating traction control – see D3 on page 74	○	○	○	○ ¹	○ ¹	○ ¹	○	○	○ ¹	○ ¹
Isolation facility for electrically operated rear windows			●	●			●	●	●	●
Electronic park/brake pedal safety interlock on models with automatic transmission	●	●	●	●	●	●	●	●	●	●
Height-adjustable centre rear seat head restraint			●	●			●	●	●	●

Security

Standard features • Remote control ultrasonic security alarm system • Remote control central deadlocking (doors, boot lid/tailgate, fuel flap) • Visible Vehicle Identification Number (VIN) plate • 'Key left in ignition' audible warning • Freewheeling driver's door lock • Electronic engine deadlock immobiliser • Door-to-door illumination – Keeps the headlights and rear lights on for 30 seconds after the car doors are locked • Foldable key • Electronic theft protection for audio equipment • Driver's internal central locking switch

Additional feature	Vectra						Signum			
	Life	Excl.	Design	Elite	SRi	SRi XP	Eleg.	Excl.	Design	Elite
Locking wheel bolts for alloy wheels (where fitted)	○	□	●	●	●	●	●	●	●	●

Interior lighting

Features	Vectra						Signum			
	Life	Excl.	Design	Elite	SRi	SRi XP	Eleg.	Excl.	Design	Elite
Fade up/fade down courtesy lights operated by front and rear door switches	●	●	●	●	●	●	●	●	●	●
Illuminated luggage area and glovebox	●	●	●	●	●	●	●	●	●	●
Map reading lights integral with front courtesy light	●	●	●	●	●	●	●	●	●	●
Two rear reading lights	●	●	●	●	●	●	●	●	●	●
Indirect night lighting			●	●				●	●	

Facia, instruments and controls

Standard features • Cruise control • Rev counter • Digital clock with automatic RDS time adjustment • Multi-function display showing time, date, audio information and outside air temperature (with ice warning function) • Steering column adjustable for reach and rake • Electronic odometer and trip odometer • Instrument panel light dimmer • Coolant temperature gauge • Handbrake-on/low brake fluid level and low fuel level warning lights

Additional features	Vectra						Signum			
	Life	Excl.	Design	Elite	SRi	SRi XP	Eleg.	Excl.	Design	Elite
Driver information centre incorporating check control warning display and multi-function trip computer ²			●	●	●	●	●	●	●	●
Three-spoke steering wheel	●	●								
Three-spoke leather-covered steering wheel			●	●			●	●		●
Three-spoke leather-covered sports steering wheel					●			●		
VXR-style three-spoke leather-covered sports steering wheel						●				
Sports instrument graphics					●	●			●	



Six airbags.

● = Standard equipment.
○ = Optional at extra cost.
□ = Only available as part of an option pack. See page 62 for details.
Excl. = Exclusiv.
Eleg. = Elegance.
SRi XP = SRi Nav with Exterior Pack.

1 = ESP-plus is standard on V6 models and available as an extra-cost option on all other models.
2 = Check control warning display features engine oil level, engine coolant level, automatic transmission control (where fitted), front brake pad wear, windscreen washer fluid level, bulb test for head/tail and brake lights, and brake lights fuse. Trip computer features instantaneous and average fuel consumption, fuel consumed, average speed, distance travelled and range based on fuel remaining.



Electro-chromatic anti-dazzle rear-view mirror.



Cruise control.

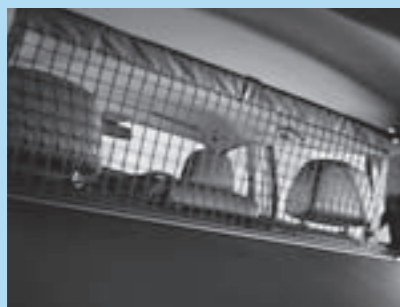

Vertical load-restraining net.

Interior features

Standard features • Front and rear tilting assist handles with damped retraction and coat hooks • Chrome internal door handles
• Colour-keyed fleece velour carpet • Lidded glovebox • Front door pockets • Hinged luggage compartment cover (hatchback)
• Retractable luggage compartment cover (estate/Signum) • Fully carpeted luggage area • Carpeted rear seat back • Drinks holders in centre console

Additional features	Life		Vectra				Signum			
	Life	Excl.	Design	Elite	SRi	SRi XP	Eleg.	Excl.	Design	Elite
Twin sunvisors incorporating front passenger's vanity mirror with cover	●									
Twin sunvisors incorporating illuminated driver's and front passenger's vanity mirrors with covers		●	●	●	●	●	●	●	●	●
Charcoal metallic-effect inserts on facia and doors	●									
Charcoal metallic/aluminium-effect inserts on facia and doors		●			●	●	●	●	●	●
Charcoal metallic/fineline dark inserts on facia and doors (with Charcoal interior trim)			●	●					●	
Wood-effect inserts on facia and doors (with Beige interior trim)				●					●	
Leather-covered gear knob (manual gearboxes only)			●	●	●			●	●	●
VXR-style leather-covered gear knob (manual gearboxes only) (exc. 1.8i 16v)						●				
Electro-chromatic anti-dazzle rear-view mirror			●	●				●	●	
Storage pocket between sunvisors ³		●	●	●	●	●	●	●	●	●

Heating and ventilation

Standard features • Air blend heater with four-speed fan • Side window demist vents and adjustable face-level air vents
• Air recirculation system with activation light • Interior pollen filter

Additional features	Life		Vectra				Signum			
	Life	Excl.	Design	Elite	SRi	SRi XP	Eleg.	Excl.	Design	Elite
Air conditioning	●	●			●	●	●	●	●	
Automatic air conditioning			●							
Electronic Climate Control (ECC) incorporating air conditioning with variable side-to-side temperature settings and dual zone sun sensor				●						●
Rear passenger compartment heating ducts			●	●						●

Seating and upholstery (see pages 52-53 for details)

Standard features • Driver's seat with reach, rake, height, tilt and lumbar adjustment • Front passenger's seat with reach and rake adjustment • Rear seat fold-down centre armrest and load-through facility • Adjustable front centre armrest with storage facility
• Storage pockets on front seat backs

Additional features	Life		Vectra				Signum			
	Life	Excl.	Design	Elite	SRi	SRi XP	Eleg.	Excl.	Design	Elite
Champion cloth seat trim	●									
Scala cloth seat trim		●					●	●		
Duke cloth seat trim					●	●				
Alpha cloth/Morrocana seat trim			●							
Draht cloth/leather seat trim									●	
Leather seat trim ⁴				●						●
Electrically heated front seats with variable temperature settings				●						●
Sports front seats					●	●			●	
Front passenger's seat with height, tilt and lumbar adjustment			●	●					●	●

Rear seating and FlexSpace®

Features	Life		Vectra				Signum			
	Life	Excl.	Design	Elite	SRi	SRi XP	Eleg.	Excl.	Design	Elite
12-volt auxiliary power socket behind front seats	●	●	●	●	●	●	●	●	●	●
Boot/luggage area sill protection	●	●	●	●	●	●	●	●	●	●
Load restraint lashing eyes	●	●	●	●	●	●	●	●	●	●
Fold-out rear seat centre armrest	●	●	●	●	●	●	●	●	●	●
Rear seat drinks holders		●	●	●	●	●	●	●	●	●
12-volt auxiliary power socket in luggage compartment (estate)		●	●	●	●	●				
Individual outer rear seats with fore and aft and recline adjustment – see D4 on page 74							●	●	●	●
Centre rear seat concealing storage console							●	●	●	●
60/40 split-folding rear seat back	●	●	●	●	●	●				
40/20/40 split-folding rear seat back							●	●	●	●
Rear seats with individual fold-flat facility – see D4 on page 74							●	●	●	●
Vertical load-restraining net (estate) ⁵	○	○	○	○	○	○				



Electrically heated seats.



Electronic Climate Control (ECC).

● = Standard equipment.
○ = Optional at extra cost.
Excl. = Excl.
Eleg. = Elegance.
SRi XP = SRi Nav with Exterior Pack.

³ = Sunroof deletes storage pocket between sunvisors.
⁴ = Seat facings and door armrests are upholstered in leather.
⁵ = Includes fixing points for accessory dog guard.



Foldable door mirrors.



Electrically operated slide/tilt glass sunroof.



Rain-sensitive windscreen wipers.

Exterior and convenience features

Standard features • Electrically operated front windows with safety autoreverse and one-touch facility • Twin electrically adjustable/heated door mirrors (wide-angle on driver's side) with automatic timed cut-off • Green-tinted glass • Heated rear window with automatic timed cut-off • Intermittent rear window wash/wipe (hatchback/estate/Signum) • Twin-jet windscreen washer nozzles • Twin gas-assisted tailgate struts (hatchback/estate/Signum) • Foldable door mirrors

Additional features	Vectra						Signum			
	Life	Excl.	Design	Elite	SRI	SRI XP	Eleg.	Excl.	Design	Elite
Rain-sensitive windscreen wipers with sensitivity adjustment and flick-wipe			●	●					●	●
Electro-chromatic anti-dazzle driver's door mirror			●	●					●	●
Two-tone horn		●	●	●	●	●	●	●	●	●
Electrically operated rear windows with safety autoreverse and child isolation facility			●	●			●	●	●	●
Electrically operated slide/tilt glass sunroof with multi-position pre-set facility and interior blind ³		○	○	○	○	○	○	○	○	○
Front and rear parking distance sensors		○	○	○	○	○	○	○	○	○
Two-coat metallic or pearlescent paint	○	○	○	○	○	○	○	●	○	○
Black roof rails (estate)	○									
Silver-effect roof rails (estate/Signum)		○	○	●	○	○	○	●	○	●
Dark-tinted Solar Protect [®] glass (excludes windscreen and front door windows) (estate/Signum)					●		●	●	●	●
Retractable tow bar (estate) ⁶	□	□	□	□	□	□				
Power tailgate (estate)			●	●						

Mechanical

Standard features • Electro-hydraulic power-assisted steering • Lightweight MacPherson strut front suspension and multi-link rear suspension with gas-pressure dampers • Catalytic converter

Additional features	Life		Vectra				Signum			
	Life	Excl.	Design	Elite	SRI	SRI XP	Eleg.	Excl.	Design	Elite
Five-speed manual gearbox (1.8i 16v VVT only)	●	●	●		●	●	●	●	●	●
Six-speed manual gearbox (exc. 1.8i 16v VVT)	●	●	●	●	●	●	●	●	●	●
Five-speed automatic transmission with Active Select function (2.2i 16v Direct models)			○	○	○	○	○	○	○	○
Six-speed automatic transmission with Active Select function (2.8i V6 24v Turbo/1.9CDTi 16v (150PS)/3.0CDTi V6 24v models)	○	○	○	○	○	○	○	○	○	○
Lowered and uprated sports suspension					●	●		●	●	
Interactive Driving System-plus (IDS-plus) with Continuous Damping Control (CDC) and Sport switch ^{7,8} - see D5 on page 75		○	○	○	○	○	○	○	○	○
Automatic self-levelling rear suspension ⁷	□	□	□	□	□	□				

Exterior lighting

Standard features • Lights-on audible warning • LED centre brake light • Twin reversing lights, rear fog light, hazard warning lights, side repeat indicators • Dual Ellipsoidal (DE) headlights • Electric headlight beam levelling

Additional features	Life		Vectra				Signum			
	Life	Excl.	Design	Elite	SRI	SRI XP	Eleg.	Excl.	Design	Elite
Adaptive Forward Lighting (AFL) incorporating bi-xenon headlights with dynamic beam levelling and high-pressure headlight washers - see D6 and D7 on page 75		○	○	○	○	○	○	○	○	○
Ellipsoidal halogen front fog lights		□	●	●	●	●		●	●	●
Automatic Lighting Control (ALC)			●	●				●	●	



Sport switch.



Adaptive Forward Lighting (AFL).

● = Standard equipment.
○ = Optional at extra cost.
□ = Only available as part of an option pack. See page 62 for details.
Excl. = Exclusiv.
Eleg. = Elegance.
SRI XP = SRI Nav with Exterior Pack.

³ = Sunroof deletes storage pocket between sunvisors.
⁶ = Please note, a separate electrical adaptor (13 pin to 7 pin) is required - available as an accessory at extra cost. This adaptor does not allow for supplementary trailer power requirements.

⁷ = Automatic self-levelling rear suspension is not available in conjunction with 18/19-inch alloy wheels, IDS-plus or sports suspension.

⁸ = Available on 2.0i 16v Turbo, 2.2i 16v Direct and 1.9CDTi 16v (150PS) models fitted with either optional ESP-plus or Towing Pack and V6 models.



W1 17-inch seven-spoke alloy wheel.



W2 17-inch seven twin-spoke alloy wheel.



W3 18-inch 11-spoke alloy wheel.

Exterior styling and protection

Standard features • Chrome-effect upper grille surround • Body-colour front and rear bumpers • Body-colour door mirrors
• Body-colour side-protection mouldings • Tailgate/boot lid push-lock • Body-colour sill mouldings and rear lower skirt
(excludes estate)

Additional features

	Vectra						Signum			
	Life	Excl.	Design	Elite	SRI	SRI XP	Eleg.	Excl.	Design	Elite
Chrome-effect lower grille surround							●	●	●	●
Chrome-effect front fog light surrounds								●	●	●
Chrome-effect window trim		●	●	●	●	●	●	●	●	●
Body-colour door handles		●	●		●	●	●	●	●	
Chrome-effect door handles				●						●
Body-colour rear lip spoiler (hatchback only)					●	●				
Body-colour sports front air dam		●	●	●	●		●	●	●	●
VXR-style sports front air dam in body colour						●				
Body-colour front lower spoiler		□	□	□	□					
Body-colour sports side sills and rear lower skirt		□	□	□	□	●				●
Dark-style headlights, tail lights and LED centre brake light with grey indicators and side repeaters					●	●			●	
White indicators and side repeaters	● ⁹	●	●		●	●	●		●	
Visible stainless steel exhaust tailpipe (hatchback/Signum)		□	□	□	●	●			●	
Visible dual branch stainless steel exhaust tailpipes (hatchback/Signum) (2.0i 16v Turbo/2.8i V6 24v Turbo/3.0CDTi V6 24v)					● ¹⁰	● ¹⁰	●		● ¹⁰	●

Wheels and tyres

Features

Features	Life	Excl.	Vectra				Signum				
			Design	Elite	SRI	SRI XP	Eleg.	Excl.	Design	Elite	
16-inch steel wheels with flush wheel covers and 205/55 R 16 ultra-low profile tyres	●										
16-inch Structure wheels with 215/55 R 16 ultra-low profile tyres		●									
16-inch seven-spoke alloy wheels with locking bolts and 215/55 R 16 ultra-low profile tyres	○		●								
17-inch seven-spoke alloy wheels with locking bolts and 215/50 R 17 ultra-low profile tyres W1		○ ¹¹	○					●			
17-inch seven twin-spoke alloy wheels with locking bolts and 215/50 R 17 bolts and 215/50 R 17 ultra-low profile tyres W2				●							●
17-inch 10-spoke alloy wheels with locking bolts and 215/50 R 17 ultra-low profile tyres					●					●	
18-inch 11-spoke alloy wheels with locking bolts and 225/45 R 18 ultra-low profile tyres ⁷ W3			○ ¹²					○ ¹²	●		
18-inch multi-spoke alloy wheels with locking bolts and 225/45 R 18 ultra-low profile tyres ⁷ W4				○ ^{11,12}		●					○ ¹²
19-inch five-spoke alloy wheels with locking bolts and 235/35 R 19 ultra-low profile tyres ^{7,13} W5						○ ¹¹	○			○	
Space-saver steel spare wheel/tyre	●	●	●	●	●	●	●	●	●	●	●
Tyre valve cap tool located behind fuel flap	●	●	●	●	●	●	●	●	●	●	●



W4 18-inch multi-spoke alloy wheel.



W5 19-inch five-spoke alloy wheel.

● = Standard equipment.
○ = Optional at extra cost.
□ = Only available as part of an option pack.
See page 62 for details.
Excl. = Exclusion.
Eleg. = Elegance.
SRI XP = SRI Nav with Exterior Pack.
⁷ = Automatic self-levelling rear suspension is not available in conjunction with 18/19-inch alloy wheels, IDS-plus or sports suspension.
⁹ = Fitted to estate models only. Hatch and saloon models are fitted with orange indicators and side repeaters.
¹⁰ = Also fitted to 2.2i 16v Direct models.
¹¹ = Also available as part of an option pack. See page 62.
¹² = Includes sports suspension.
¹³ = Not available on 3.0CDTi V6 24v models. The optional 19-inch alloy wheels will affect the fuel consumption and CO₂ emissions (see pages 67/68). This may have an effect on the VED band and/or benefit in kind taxation. (See Vauxhall Car and Accessory Price Guide for details).

● = Standard equipment
○ = Optional at extra cost
Excl. = Exclusiv.
SRiXP = SRi Nav with Exterior Pack

- 3 = Sunroof deletes storage pocket between sunvisors.
- 6 = Please note: a separate electrical adaptor (13-pin to 7-pin) is required – available as an accessory at extra cost. This adaptor does not allow for supplementary trailer power requirements.
- 7 = Automatic self-levelling rear suspension is not available in conjunction with 18/19-inch alloy wheels, IDS-plus or sports suspension.
- 12 = Includes sports suspension.
- 13 = Not available on 3.0CDTi V6 24v models. The optional 19-inch alloy wheels will affect the fuel consumption and CO₂ emissions (see pages 67/68). This may have an effect on the VED band and/or benefit in kind taxation. (See Vauxhall Car and Accessory Price Guide for details).
- 14 = Not available on SRi Nav.
- 15 = ESP-plus is standard on 2.8i V6 24v Turbo/ 3.0CDTi V6 24v models.
- 16 = Please note: extra-cost option packs are only available on Vectra models.

Option packs¹⁶

	Vectra					
	Life	Excl.	Design	Elite	SRi	SRiXP
Plus Pack (Exclusiv) • 17-inch alloy wheels (steel space-saver spare) with 215/50 R 17 tyres • Locking wheel bolts • CDC 40 stereo radio with Digital Audio Broadcast (DAB)/integral six-disc CD autochanger with MP3 format/graphic display • Front fog lights		○				
Plus Pack (Elite) • 18-inch alloy wheels (steel space-saver spare) with 225/45 R 18 tyres • Electrically operated slide/tilt glass sunroof with multi-position pre-select facility ³				○ ¹²		
Plus Pack (SRi)¹³ • 19-inch alloy wheels (steel space saver spare) with 235/35 R 19 tyres • CDC 40 stereo radio with Digital Audio Broadcast (DAB)/integral six-disc CD autochanger with MP3 format/graphic display					○ ¹⁴	
VXR Styling Pack One (hatch/estate) • Body-colour front spoiler, side sills, rear spoiler (standard on SRi hatch) and rear lower skirt • Visible stainless steel exhaust tailpipe (hatch)		○	○	○	○	
Towing Pack (estate) • Electronic Stability Programme-plus (ESP-plus) • Trailer stability programme • Automatic self-levelling rear suspension ⁷ • Retractable tow bar ⁶	○	○	○	○ ¹⁵	○ ¹⁵	○ ¹⁵
FlexOrganiser® Pack (estate) • 3D storage net • Side net pocket • Four side rail hooks	○	○	○	○	○	○

Plus Pack (Exclusiv)

- 17-inch alloy wheels with 215/50 R 17 tyres
- CDC 40 stereo radio with DAB/integral six-disc CD autochanger with MP3 format/graphic display
- Front fog lights
- Locking wheel bolts

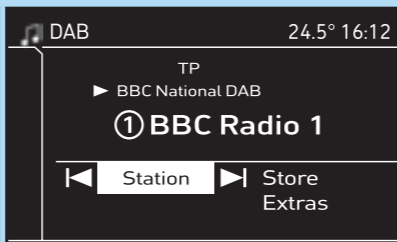

Plus Pack (Elite)

- 18-inch alloy wheels with 225/45 R 18 tyres
- Electrically operated slide/tilt glass sunroof



Plus Pack (SRi)

- 19-inch alloy wheels with 235/35 R 19 tyres
- CDC 40 stereo radio with DAB/integral six-disc CD autochanger with MP3 format/graphic display



VXR Styling Pack One (hatch/estate)

- Front lower spoiler
- Rear spoiler
- Side sills
- Rear lower skirt
- Visible stainless steel exhaust tailpipe (hatch)



Towing Pack (estate)

- Electronic Stability Programme-plus incorporating traction control
- Trailer stability programme
- Automatic self-levelling rear suspension
- Retractable tow bar

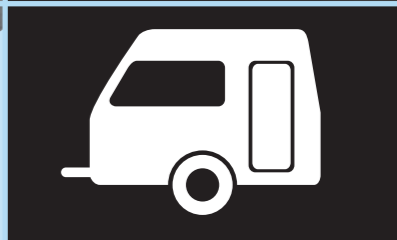

FlexOrganiser® Pack (estate)

- 3D storage net
- Side net pocket
- Four side rail hooks



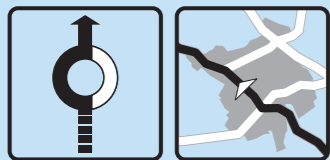

Colour Sat Nav

Standard on all Signum models and Vectra Design Nav/Elite/SRi Nav

Vectra Nav models

Available as additional models to the range, Vectra Life Nav, Exclusiv Nav, Design Nav and SRi Nav feature the CD 70 stereo radio/CD player/satellite navigation system as standard. Life and Exclusiv Nav models are fitted with a graphic display, while Design and SRi Nav feature a colour monitor.



CD 70 satellite navigation with colour monitor.

Audio, communication and navigation

Features	Life		Vectra				Signum			
	Life	Excl.	Design	Elite	SRi	SRi XP	Eleg.	Excl.	Design	Elite
CD 30 stereo radio/CD player • AM/FM stereo radio with 24 station presets • RDS with Traffic Programme CD player • Remote display • 17 watts per channel output • 6 speakers (7 on SRi models)	●	●			●					
CDC 40 DAB stereo radio/CD autochanger with MP3 format (deletes auxiliary-in socket where fitted) • AM/FM/DAB (Digital Audio Broadcast) stereo radio with 36 station presets • RDS with Traffic Programme • Integral six-disc CD autochanger with MP3 format • Remote graphic display • 35 watts per channel output • 7 speakers	○	○ ¹¹	●	N/C ¹⁷	○ ^{11, 14}		N/C ¹⁷	N/C ¹⁷	N/C ¹⁷	N/C ¹⁷
CD 70 stereo radio/CD player with MP3 format/satellite navigation • AM/FM stereo radio with 40 station presets • RDS with Traffic Programme • CD player with MP3 format • Auxiliary-in socket • Satellite navigation system • Remote colour monitor • 20 watts per channel output • 7 speakers			● ¹⁸	●	● ¹⁸	●	●	●	●	●
CD 70 stereo radio/CD player with MP3 format/satellite navigation • AM/FM stereo radio with 40 station presets • RDS with Traffic Programme • CD player with MP3 format • Auxiliary-in socket • Satellite navigation system • Remote graphic display • 20 watts per channel output • 7 speakers	● ¹⁸	● ¹⁸								
Colour monitor for CD 70	○ ¹⁹	○ ¹⁹	● ¹⁸	●	● ¹⁸	●	●	●	●	●
Steering wheel mounted audio controls	●	●	●	●	●	●	●	●	●	●
Roof-mounted flexible aerial	●	●	●	●	●	●	●	●	●	●
Mobile phone system with Bluetooth® (does not include phone or cradle) ²⁰	○	○	○	○	○	○	○	○	○	○

Satellite navigation

The CD 70 satellite navigation system uses the international network of GPS (Global Positioning System) satellites, linked to a comprehensive CD-ROM mapping system, to determine your precise location and guide you to your chosen destination virtually anywhere in mainland Britain.

Vauxhall's CD-ROM-driven satellite navigation systems have been widely acclaimed for their ease of use and high level of information. The colour monitor has a split-screen facility to display half the screen as a map and half as easy-to-follow directional arrows. The audible direction guidance prompt gives details of road numbers and motorway junction numbers, while you can also plan your route to avoid toll roads, if required.

The CD 70 also features Traffic Message Channel (TMC), a specific application of RDS used for broadcasting real-time traffic information, delivered to the driver either visually or verbally. TMC can also offer dynamic route guidance – alerting the driver to a problem on the planned route and calculating an alternative route to avoid the incident.

Standard features • Automatic re-routing on request • CD-ROMs available for all major European countries • Exact location of vehicle using the GPS (Global Positioning System) and speed sensor • Choice of four different route types • Store up to 100 personal destinations • Last 10 destinations stored automatically

Digital Audio Broadcast (DAB) facility

Now widely available in the UK, digital audio broadcasts offer the user a variety of advantages over traditional FM, starting with the digital quality sound which is immune to any hiss or crackle.

You'll often find a broader range of stations on offer too, many of which are not available on FM, and listening to them couldn't be easier – you simply select the station, by name, from the displayed list, thus removing the need to retune or look for stations when travelling around. Some stations will even display the artists' names and song titles on the car's graphic display, while they're played.

To further help you appreciate the digital sound, our CDC 40 DAB-compatible audio unit offers 35 watts per channel and plays through our highest quality seven-speaker system.

Auxiliary-in socket

The auxiliary-in socket allows you to connect your portable MP3 music player directly into the car's audio system. All you need is your music player and a suitable connecting lead and you can listen to all your favourite tunes through your car's speaker system.

When using an MP3 player in the car the majority of the controls, such as track selection, remain solely on the player, while only the volume is controlled via the car's regular audio controls.

Mobile phone system with Bluetooth®

Vauxhall's factory-fit dual-band mobile phone system has been considerably enhanced. Now fully integrated into the audio and communication system, it also features voice control and will connect wirelessly to phones with Bluetooth® technology.

All the required information is displayed on the graphic information display when a mobile phone is in use, while the menus are easily navigated by either the steering wheel audio controls or the multi-function button on the radio. Certain functions can also be controlled by voice activation.

Mounted on the centre console, the phone system base unit can be fitted with a cradle (available as an accessory) for many different mobile phones. A list of compatible cradles is featured in the Car and Accessory Price Guide.

MP3 CD player

An MP3 is a compressed sound or music file which, due to its small size, takes up less space on a compact disc, which means that more tracks can be recorded onto a CD.

It's possible to fit almost 10 hours of music onto one CD, and, in a way, turns a single-disc CD/MP3 player into a multi-disc autochanger.



CD 70 satellite navigation split-screen facility.



Mobile phone system with Bluetooth®.

● = Standard equipment.
○ = Optional at extra cost.
N/C = No-cost option.
Excl. = Exclusiv.
Eleg. = Elegance.
SRi XP = SRi Nav with Exterior Pack.

¹¹ = Also available as part of an extra-cost option pack. See page 62 for details.
¹⁴ = Not available on SRi Nav.
¹⁷ = Fitted in lieu of CD 70 audio system. Deletes the satellite navigation function.
¹⁸ = Standard on Nav models.
¹⁹ = Available on Nav models only.
²⁰ = Deletes drinks holders in centre console.

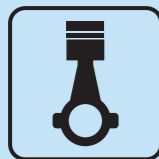

350Nm
2.8i V6 24v Turbo
– maximum torque
at only 1800rpm

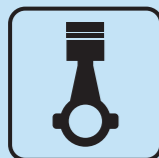

184PS
3.0CDTi V6 24v –
now more powerful
and more efficient

Petrol engines

	1.8i 16v VVT ECOTEC-4	2.2i 16v Direct ECOTEC-4 aluminium	2.0i 16v Turbo ECOTEC-4 aluminium	2.8i V6 24v Turbo ECOTEC-4 Turbo
Capacity	1796cc	2198cc	1998cc	2792cc
Maximum power	140PS (103kW) @ 6300rpm	155PS (114kW) @ 5600rpm	175PS (129kW) @ 5500rpm	250PS (184kW) @ 5500rpm
Maximum torque	175Nm (129 lb.ft.) @ 3800rpm	220Nm (162 lb.ft.) @ 3800rpm	265Nm (195 lb.ft.) @ 2500rpm	350Nm (258 lb.ft.) @ 1800rpm
Layout	4 cylinders 4 valves per cylinder Double overhead camshafts	4 cylinders 4 valves per cylinder Double overhead camshafts	4 cylinders 4 valves per cylinder Double overhead camshafts	6 cylinders 4 valves per cylinder Double overhead camshafts
Fuel/induction system	Naturally aspirated Variable Valve Timing (VVT) Multi-point sequential fuel injection	Naturally aspirated Direct fuel injection	Water-cooled turbocharger with intercooler Multi-point sequential fuel injection	Water-cooled twin-scroll turbocharger with intercooler Multi-point sequential fuel injection
Service interval	20,000 miles or 1 year (whichever occurs sooner)			
<i>Benefit in kind company car taxation – 2007/08 tax year</i>				
Hatchback/Saloon/Estate/Signum				
Manual*	21/21/23/23	23/23/24/25	28/-/29/29	-/-/-/35
Automatic*	-/-/-/-	25/25/26/26	-/-/-/-	35/-/35/35

Diesel engines

	1.9CDTi (120PS) ECOTEC-4 turbo diesel	1.9CDTi 16v (150PS) ECOTEC-4 turbo diesel	3.0CDTi V6 24v ECOTEC-V6 turbo diesel
Capacity	1910cc	1910cc	2958cc
Maximum power	120PS (88kW) @ 3500rpm	150PS (110kW) @ 4000rpm	184PS (135kW) @ 4000rpm
Maximum torque	280Nm (206 lb.ft.) @ 2000-2750rpm	320Nm (235 lb.ft.) @ 2000-2750rpm	400Nm (295 lb.ft.) @ 1900-2700rpm
Layout	4 cylinders 2 valves per cylinder Single overhead camshaft	4 cylinders 4 valves per cylinder Double overhead camshafts	6 cylinders 4 valves per cylinder Double overhead camshafts
Fuel/induction system	Variable geometry turbocharger with intercooler. Common rail fuel injection		
Service interval	20,000 miles or 1 year (whichever occurs sooner)		
<i>Benefit in kind company car taxation – 2007/08 tax year</i>			
Hatchback/Saloon/Estate/Signum			
Manual*	20/20/21/21	20/20/21/21	27/-/27/27
Automatic*	-/-/-/-	27/26/27/27	28/-/28/28

- = This engine/body style/transmission combination is not available.
* = For details of benefit in kind percentage rates relating to models fitted with optional 19-inch alloy wheels please refer to the Vauxhall Car and Accessory Price Guide.

Petrol engine performance, fuel economy and emissions

	Performance (manufacturer's figures)			Wheel size (inches)	Fuel economy mpg (litres/100km)			CO ₂ emissions g/km
	Maximum speed (mph)	Acceleration (sec) 0-60mph	30-50mph (4th gear)		Urban driving	Extra-urban driving	Combined figure	
<i>Manual gearbox</i>								
1.8i 16v VVT Vectra hatch/saloon	131	10.2	8.6	16/17/18	28.0 (10.1)	51.4 (5.5)	39.2 (7.2)	173
				19	27.7 (10.2)	50.4 (5.6)	38.7 (7.3)	175
1.8i 16v VVT Vectra estate	126	10.7	9.2	16/17/18	27.4 (10.3)	47.9 (5.9)	37.7 (7.5)	180
				19	27.2 (10.4)	47.1 (6.0)	37.2 (7.6)	182
1.8i 16v VVT Signum	125	10.8	9.6	17/18	27.4 (10.3)	47.9 (5.9)	37.7 (7.5)	180
2.2i 16v Direct Vectra hatch/saloon	135	8.6	7.5	16/17/18	27.4 (10.3)	47.9 (5.9)	37.7 (7.5)	180
				19	27.2 (10.4)	47.1 (6.0)	37.2 (7.6)	182
2.2i 16v Direct Vectra estate	130	8.9	7.2	16/17/18	26.6 (10.6)	45.6 (6.2)	36.2 (7.8)	187
				19	26.4 (10.7)	44.8 (6.3)	35.8 (7.9)	190
2.2i 16v Direct Signum	130	9.1	7.5	17/18	25.9 (10.9)	43.5 (6.5)	34.9 (8.1)	194
				19	25.7 (11.0)	42.8 (6.6)	34.4 (8.2)	197
2.0i 16v Turbo Vectra hatch	143	8.1	5.5	17/18	22.6 (12.5)	44.8 (6.3)	32.8 (8.6)	206
				19	22.4 (12.6)	44.1 (6.4)	32.5 (8.7)	209
2.0i 16v Turbo Vectra estate	139	8.4	5.9	17/18	22.2 (12.7)	43.5 (6.5)	32.1 (8.8)	211
				19	22.1 (12.8)	42.8 (6.6)	31.7 (8.9)	214
2.0i 16v Turbo Signum	137	8.4	5.9	17/18	22.1 (12.8)	42.8 (6.6)	31.7 (8.9)	214
				19	21.9 (12.9)	42.2 (6.7)	31.4 (9.0)	216
2.8i V6 24v Turbo Signum	155	6.7	4.9	17/18	18.0 (15.7)	37.2 (7.6)	26.6 (10.6)	254
				19	17.9 (15.8)	36.7 (7.7)	26.4 (10.7)	257
<i>Automatic transmission</i>								
2.2i 16v Direct Vectra hatch/saloon	130	9.5	-	16/17/18	25.0 (11.3)	46.3 (6.1)	35.3 (8.0)	192
				19	24.8 (11.4)	45.6 (6.2)	34.9 (8.1)	194
2.2i 16v Direct Vectra estate	129	9.9	-	16/17/18	24.6 (11.5)	44.8 (6.3)	34.4 (8.2)	197
				19	24.4 (11.6)	44.1 (6.4)	34.0 (8.3)	199
2.2i 16v Direct Signum	128	10.0	-	17/18	24.4 (11.6)	44.1 (6.4)	34.0 (8.3)	199
				19	24.1 (11.7)	43.5 (6.5)	33.6 (8.4)	202
2.8i V6 24v Turbo Vectra hatch	155	6.8	-	17/18	16.5 (17.1)	38.7 (7.3)	25.9 (10.9)	262
2.8i V6 24v Turbo Vectra estate	155	7.0	-	17/18	16.2 (17.4)	37.2 (7.6)	25.2 (11.2)	269
2.8i V6 24v Turbo Signum	153	7.1	-	17/18	16.2 (17.4)	37.2 (7.6)	25.2 (11.2)	269

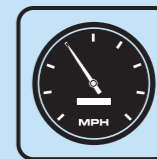

6.7secs
Signum 2.8i V6 24v
Turbo 0-60mph



60.1mpg
Vectra 1.9CDTi engines are both powerful and economical



5.3secs
Vectra 3.0CDTi V6 24v hatch 30-50mph, great torque and flexibility

Diesel engine performance, fuel economy and emissions

	Performance (manufacturer's figures)			Wheel size (inches)	Fuel economy mpg (litres/100km)			CO ₂ emissions g/km
	Maximum speed (mph)	Acceleration (sec) 0-60mph	30-50mph (4th gear)		Urban driving	Extra-urban driving	Combined figure	
Manual gearbox								
1.9CDTi (120PS) Vectra hatch/saloon	124	10.5	7.5	16/17/18	38.2 (7.4)	60.1 (4.7)	49.6 (5.7)	154
				19	37.7 (7.5)	58.9 (4.8)	48.7 (5.8)	157
1.9CDTi (120PS) Vectra estate	121	11.2	8.0	16/17/18	37.7 (7.5)	58.9 (4.8)	48.7 (5.8)	157
				19	37.2 (7.6)	57.6 (4.9)	47.9 (5.9)	159
1.9CDTi (120PS) Signum	120	11.2	8.1	17/18	37.2 (7.6)	57.6 (4.9)	47.9 (5.9)	159
				19	36.7 (7.7)	56.5 (5.0)	47.1 (6.0)	162
1.9CDTi 16v (150PS) Vectra hatch/saloon	135	8.9	6.2	16/17/18	38.2 (7.4)	60.1 (4.7)	49.6 (5.7)	154
				19	37.7 (7.5)	58.9 (4.8)	48.7 (5.8)	157
1.9CDTi 16v (150PS) Vectra estate	130	9.5	6.5	16/17/18	37.7 (7.5)	58.9 (4.8)	48.7 (5.8)	157
				19	37.2 (7.6)	57.6 (4.9)	47.9 (5.9)	159
1.9CDTi 16v (150PS) Signum	129	9.5	6.7	17/18	37.2 (7.6)	57.6 (4.9)	47.9 (5.9)	159
				19	36.7 (7.7)	56.5 (5.0)	47.1 (6.0)	162
3.0CDTi V6 24v Vectra hatch	143	8.2	5.3	17/18	28.8 (9.8)	54.3 (5.2)	40.9 (6.9)	186
3.0CDTi V6 24v Vectra estate	140	8.6	5.6	17/18	28.8 (9.8)	54.3 (5.2)	40.9 (6.9)	186
3.0CDTi V6 24v Signum	139	8.7	5.7	17/18	28.5 (9.9)	53.3 (5.3)	40.4 (7.0)	189
Automatic transmission								
1.9CDTi 16v (150PS) Vectra hatch	130	9.4	-	16/17/18	29.7 (9.5)	52.3 (5.4)	40.9 (6.9)	186
				19	29.4 (9.6)	51.4 (5.5)	40.4 (7.0)	189
1.9CDTi 16v (150PS) Vectra saloon	130	9.4	-	16/17/18	30.1 (9.4)	53.3 (5.3)	41.5 (6.8)	184
				19	29.7 (9.5)	52.3 (5.4)	40.9 (6.9)	186
1.9CDTi 16v (150PS) Vectra estate	129	9.7	-	16/17/18	29.4 (9.6)	51.4 (5.5)	40.4 (7.0)	189
				19	29.1 (9.7)	50.4 (5.6)	39.8 (7.1)	192
1.9CDTi 16v (150PS) Signum	127	9.7	-	17/18	29.4 (9.6)	51.4 (5.5)	40.4 (7.0)	189
				19	29.1 (9.7)	50.4 (5.6)	39.8 (7.1)	192
3.0CDTi V6 24v Vectra hatch	140	8.6	-	17/18	27.7 (10.2)	53.3 (5.3)	39.8 (7.1)	192
3.0CDTi V6 24v Vectra estate	137	8.9	-	17/18	27.4 (10.3)	52.3 (5.4)	39.2 (7.2)	194
3.0CDTi V6 24v Signum	136	8.9	-	17/18	27.4 (10.3)	52.3 (5.4)	39.2 (7.2)	194

The fuel consumption figures shown comply with EC directive 1999/100 to provide a realistic indication of fuel consumption by taking into account everyday driving conditions, such as cold starts, acceleration and braking. These figures take account of the vehicles kerbweight, ascertained in accordance with the above regulation. **Important:** the results given relate to the particular car tested. Driving style, road and traffic conditions, vehicle mileage and standard of maintenance may also affect fuel consumption; therefore the results do not express or imply any guarantee of fuel consumption attainable.

Vauxhall Assistance and warranties*

- A one-year unlimited mileage manufacturer's warranty
- Second and third year no-fee customer option warranty up to 60,000 miles (from first registration)
- Vauxhall Assistance for 12 months from first registration
- Six years' body panel anti-perforation warranty

* = Warranty is only available on vehicles sourced from Vauxhall Motors Ltd. Terms and conditions apply - please see your Vauxhall retailer for details.

Optional transmissions

Five-speed automatic transmission with Active Select function: available at extra cost on 2.2i 16v Direct models. Electronically controlled with adaptive driving function and winter mode. Fluid drive with torque converter, lock-up clutch, neutral control fuel-saving feature and Active Select.

Six-speed automatic transmission with Active Select function: standard on 2.8i V6 24v Turbo Elite models and available at extra cost on 1.9CDTi 16v (150PS)/3.0CDTi V6 24v models. Electronically controlled with adaptive driving function and winter mode. Fluid drive with torque converter, lock-up clutch, neutral control fuel-saving feature and Active Select.

Suspension

Front: Independent. Lightweight MacPherson struts with gas-pressure dampers and coil springs. Anti-roll bar.

- Vectra SRI/Signum Exclusiv and Design - uprated springs and dampers with lower ride height

Rear: Lightweight multi-link with rising-rate mini-block coil springs and gas-pressure dampers. Compact packaging ensures minimal intrusion into luggage area.

- Vectra SRI/Signum Exclusiv and Design - uprated springs and dampers with lower ride height
- Vectra Life, Exclusiv, Design and Elite estate - automatic self-levelling rear suspension optional as part of Towing Pack

Fuel tank capacity

- Vectra hatchback/saloon - 61 litres (13.4 gallons)
- Vectra estate/Signum - 60 litres (13.2 gallons)

Brakes

- Anti-lock Braking System (ABS)
- Dual circuit, diagonally split braking system

1.8i 16v VVT/2.2i 16v/1.9CDTi (120/150PS)
Front ventilated discs: 285mm diameter
Rear discs: 278mm diameter

2.0i 16v Turbo
Front ventilated discs: 302mm diameter
Rear ventilated discs: 292mm diameter

2.8i V6 24v Turbo/3.0CDTi V6 24v
Front ventilated discs: 314mm diameter
Rear ventilated discs: 292mm diameter

Steering

- Electro-hydraulic power-assisted steering - all engines (exc. 2.8i V6 24v)
- Hydraulic power-assisted steering - 2.8i V6 24v

• Turning circle (kerb-to-kerb):

Vectra hatch/saloon

Life/Exclusiv/Design/Elite - 11.25m (36.9ft)
SRI - 11.35m (37.2ft)

Vectra estate

Life/Design/Elite - 11.70m (38.4ft)
SRI - 11.80m (38.7ft)

Signum

All models - 11.70m (38.4ft)

Body

- Aerodynamic drag co-efficients:
Hatchback/Saloon - Cd 0.29
Estate - Cd 0.32
Signum - Cd 0.33

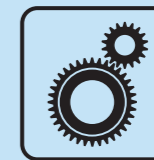

6-Speed
Six-speed manual and automatic transmissions widely available

Exterior dimensions millimetres (inches)

Vectra hatchback

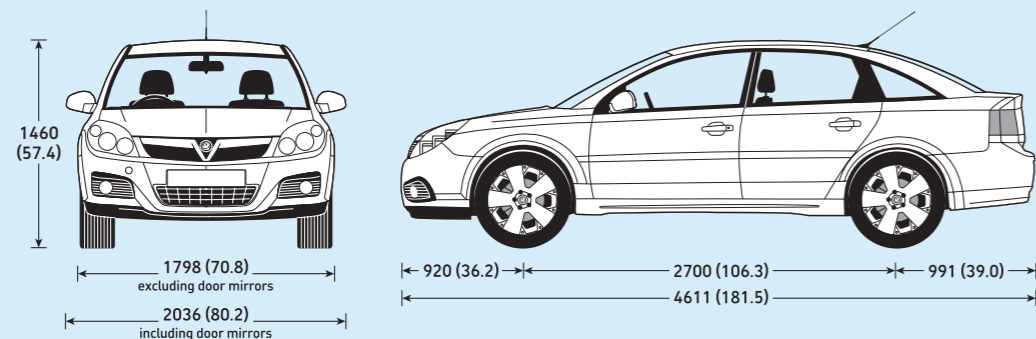

Vectra saloon

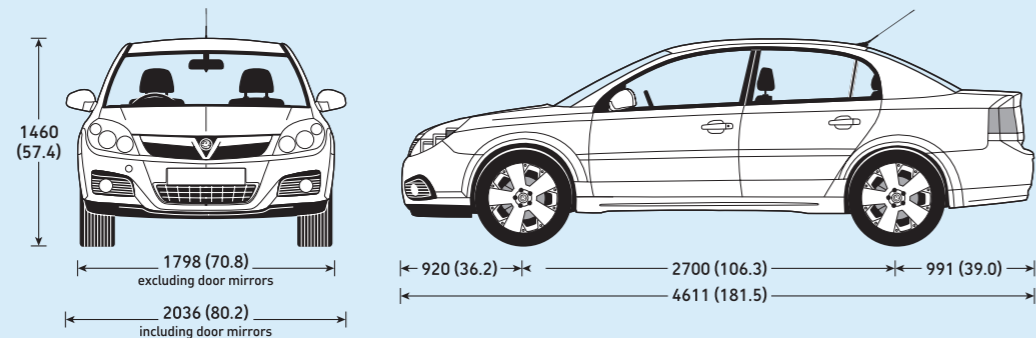

Vectra estate

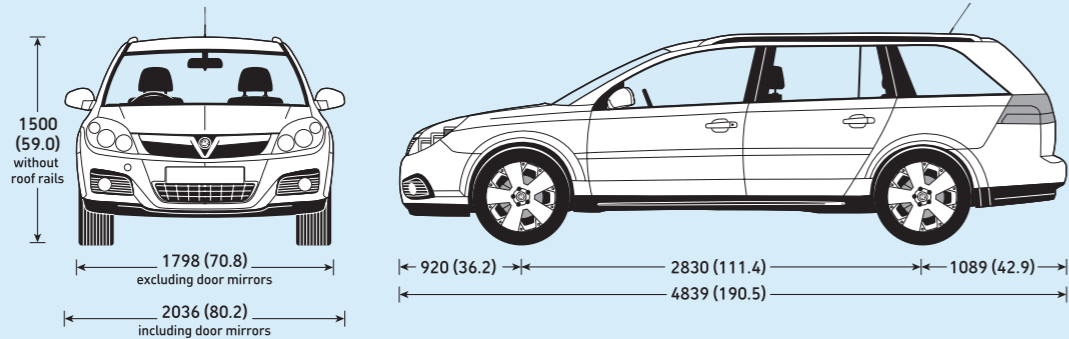

Exterior dimensions millimetres (inches)

Signum

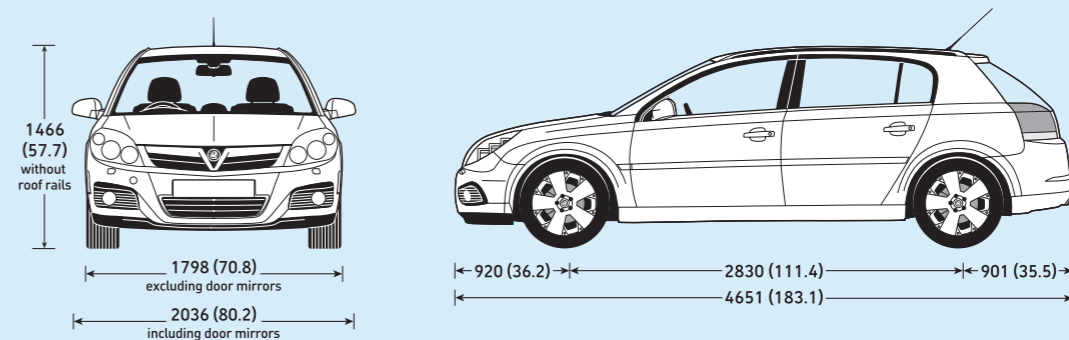

Loadspace dimensions millimetres (inches)

	Vectra Estate	Signum
Maximum load floor length – rear seats folded (A)	2046 (80.6)	1833 (72.2)
Maximum load floor length – rear seats up and fully back	1175 (46.3)	931 (36.7)
Maximum load floor length – rear seats up and fully forward	-	1061 (41.8)
Maximum rear floor width (B)	1079 (42.5)	1054 (41.5)
Maximum rear floor width (C)	1060 (41.7)	978 (38.5)
Maximum load area height (D)	850 (33.5)	761 (30.0)

	Vectra Estate	Signum
Loading height from ground level (unladen) (E)	608 (23.9)	599 (23.6)
Maximum tailgate aperture width	1089 (42.9)	1035 (40.7)
Maximum tailgate aperture height	767 (30.2)	727 (28.6)
Maximum load area height beneath luggage compartment cover	472 (18.6)	505 (19.9)

- = This dimension does not apply to this bodystyle.

Interior dimensions millimetres (inches)

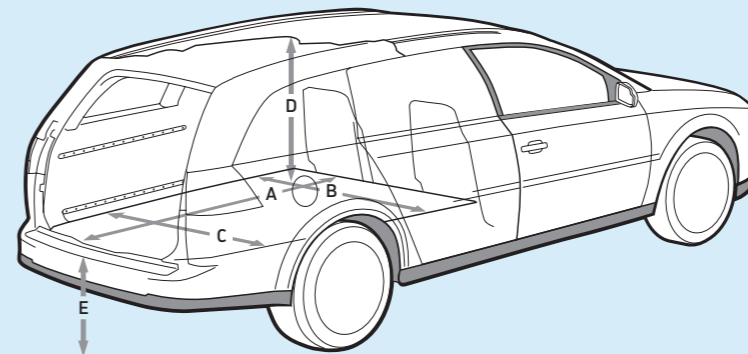

Luggage capacities* litres (cu.ft.)

	Load volume (minimum)**	Load volume (maximum)†
Vectra hatch	500 (17.7)	1050 (37.1)
Vectra saloon	500 (17.7)	1050 (37.1)
Vectra estate	530 (18.7)	1850 (65.3)
Signum	365 (12.9)	1410 (49.8)

* = Measured using the ECIE method
 ** = Under luggage cover – rear seats up
 † = To roof – rear seats folded.

Weights and towing data (petrol engines) kg

	Kerbweight (Gross vehicle weight)				Max. towing weights Trailer with brakes (without brakes)		
	Hatchback	Saloon	Estate	Signum	Hatchback/Sal.	Estate	Signum
	1.8i 16v VVT Life/Elegance/Exclusiv	1335 (1885)	1336 (1870)	1400 (2030)	1438 (2020)	1400 (685)	1300 (735)
1.8i 16v VVT Design	1350 (1885)	1352 (1870)	1431 (2030)	-	1400 (685)	1300 (735)	-
1.8i 16v VVT SRi	1346 (1885)	-	1428 (2030)	-	1300 (685)	1300 (735)	-
2.2i 16v Direct Elegance/Exclusiv	-	-	-	1493 (2075)	-	-	1500 (750)
2.2i 16v Direct Elegance/Exclusiv (auto)	-	-	-	1523 (2105)	-	-	1600 (750)
2.2i 16v Direct Design	1431 (1950)	1416 (1935)	1459 (2085)	1494 (2075)	1500 (715)	1600 (750)	1500 (750)
2.2i 16v Direct Design (auto)	1461 (1980)	1446 (1965)	1509 (2115)	1524 (2105)	1600 (715)	1600 (750)	1600 (750)
2.2i 16v Direct Elite	1431 (1950)	1416 (1935)	1459 (2085)	1499 (2075)	1500 (715)	1600 (750)	1500 (750)
2.2i 16v Direct Elite (auto)	1461 (1980)	1446 (1965)	1509 (2115)	1529 (2105)	1600 (715)	1600 (750)	1600 (750)
2.2i 16v Direct SRi	1428 (1950)	-	1456 (2085)	-	1500 (715)	1600 (750)	-
2.2i 16v Direct SRi (auto)	1455 (1980)	-	1506 (2115)	-	1600 (715)	1600 (750)	-
2.0i 16v Turbo Elegance	-	-	-	1518 (2100)	-	-	1700 (750)
2.0i 16v Turbo Design	-	-	-	1519 (2100)	-	-	1700 (750)
2.0i 16v Turbo Elite	-	-	-	1524 (2100)	-	-	1700 (750)
2.0i 16v Turbo SRi	1456 (1995)	-	1523 (2125)	-	1600 (730)	1700 (750)	-
2.8i V6 24v Turbo Design	-	-	-	1594 (2175)	-	-	1700 (750)
2.8i V6 24v Turbo Elite (auto)	1561 (2080)	-	1594 (2215)	1619 (2200)	1600 (750)	1800 (750)	1700 (750)

Gross vehicle weight is the total permissible weight of the vehicle including passengers and their luggage. To determine total carrying capacity, deduct kerbweight from gross vehicle weight. Note that the figure obtained will include the weight of the driver, passengers and any optional equipment or accessories. The **maximum roof rack loading** should not exceed 90kg for Vectra hatchback and saloon models, or 100kg for Vectra estate and Signum models. The **maximum towing weights** are based on the ability of the car, with two occupants of 70kg each, to restart on a 12% gradient, which is approximately 1 in 8.3, at sea level. At altitudes above 1500 metres, the engine output may drop with a corresponding reduction in towing capability. Any extra weight, such as luggage or additional passengers, should be deducted from the maximum towing weight. With a trailer fully loaded, **maximum noseweight** should not exceed 78kg for Vectra hatchback and saloon and Signum models, or 85kg for Vectra estate models. Always fit Vauxhall towing attachments and accessories available from your Vauxhall retailer. They are designed specifically for Vauxhall models and carry a 12-month guarantee.

Weights and towing data (diesel engines) kg

	Kerbweight (Gross vehicle weight)				Max. towing weights Trailer with brakes (without brakes)		
	Hatchback	Saloon	Estate	Signum	Hatchback/Sal.	Estate	Signum
	1.9CDTi (120PS) Life/Elegance/Exclusiv	1428 (1995)	1430 (1980)	1510 (2140)	1548 (2130)	1500 (750)	1500 (750)
1.9CDTi (120PS) Design	1459 (1995)	1461 (1980)	1541 (2140)	1549 (2130)	1500 (750)	1500 (750)	1500 (750)
1.9CDTi (120PS) SRi	1456 (1995)	-	1538 (2140)	-	1500 (750)	1500 (750)	-
1.9CDTi 16v (150PS) Life/Exclusiv	1428 (2005)	1430 (1990)	1525 (2155)	1556 (2145)	1600 (750)	1500 (750)	1500 (750)
1.9CDTi 16v (150PS) Life/Elegance/Exclusiv (auto)	1473 (2030)	1430 (2015)	1538 (2180)	1581 (1270)	1600 (750)	1500 (750)	1500 (750)
1.9CDTi 16v (150PS) Design	1459 (2005)	1461 (1990)	1556 (2155)	1557 (2145)	1600 (750)	1500 (750)	1600 (750)
1.9CDTi 16v (150PS) Design (auto)	1504 (2030)	1461 (2015)	1569 (2180)	1582 (2170)	1600 (750)	1500 (750)	1600 (750)
1.9CDTi 16v (150PS) Elite	1459 (2005)	1461 (1990)	1556 (2155)	1562 (2145)	1600 (750)	1500 (750)	1600 (750)
1.9CDTi 16v (150PS) Elite (auto)	1504 (2030)	1461 (2015)	1569 (2180)	1587 (2170)	1600 (750)	1500 (750)	1600 (750)
1.9CDTi 16v (150PS) SRi	1456 (2005)	-	1553 (2155)	-	1600 (750)	1500 (750)	-
1.9CDTi 16v (150PS) SRi (auto)	1501 (2030)	-	1566 (2180)	-	1600 (750)	1500 (750)	-
3.0CDTi V6 24v Design	-	-	-	1659 (2240)	-	-	1700 (750)
3.0CDTi V6 24v Design (auto)	-	-	-	1677 (2265)	-	-	1300 (750)
3.0CDTi V6 24v Elite	1596 (2125)	-	1631 (2240)	1664 (2240)	1600 (750)	1800 (750)	1700 (750)
3.0CDTi V6 24v Elite (auto)	1621 (2150)	-	1656 (2265)	1682 (2265)	1400 (750)	1200 (750)	1300 (750)
3.0CDTi V6 24v SRi	1593 (2125)	-	1636 (2240)	-	1600 (750)	1800 (750)	-
3.0CDTi V6 24v SRi (auto)	1618 (2150)	-	1661 (2265)	-	1400 (750)	1200 (750)	-

Gross vehicle weight is the total permissible weight of the vehicle including passengers and their luggage. To determine total carrying capacity, deduct kerbweight from gross vehicle weight. Note that the figure obtained will include the weight of the driver, passengers and any optional equipment or accessories. The **maximum roof rack loading** should not exceed 90kg for Vectra hatchback and saloon models, or 100kg for Vectra estate and Signum models. The **maximum towing weights** are based on the ability of the car, with two occupants of 70kg each, to restart on a 12% gradient, which is approximately 1 in 8.3, at sea level. At altitudes above 1500 metres, the engine output may drop with a corresponding reduction in towing capability. Any extra weight, such as luggage or additional passengers, should be deducted from the maximum towing weight. With a trailer fully loaded, **maximum noseweight** should not exceed 78kg for Vectra hatchback and saloon and Signum models, or 85kg for Vectra estate models. Always fit Vauxhall towing attachments and accessories available from your Vauxhall retailer. They are designed specifically for Vauxhall models and carry a 12-month guarantee.

Features explained

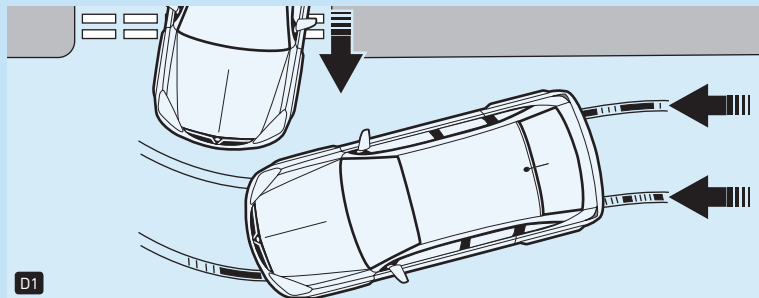

Anti-lock Braking System (ABS) with Cornering Brake Control (CBC)

D1. Cornering brake control makes the car easier to control in extreme situations, particularly when braking sharply on a bend. It is particularly effective when carrying out emergency procedures, such as avoiding a child's ball that's rolled out from the kerb. The system works by sensing the different rotational speeds of the individual road wheels and co-ordinating the level of braking pressure applied to each wheel. CBC is an integral part of Vectra and Signum's comprehensive ABS.

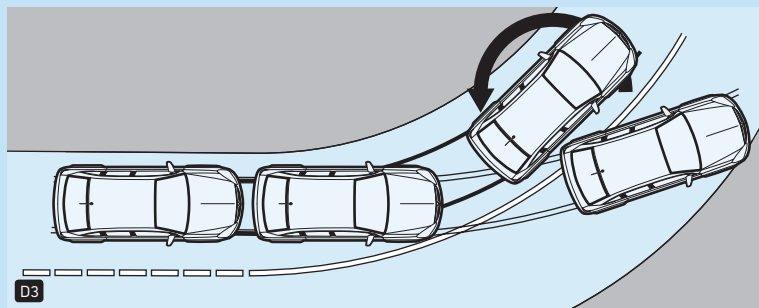

Electronic Stability Programme-plus (ESP-plus)

D3. ESP-plus provides enhanced yaw compensation during understeer or oversteer. The system works by monitoring the front and rear of the car, comparing their respective directions of travel going in to the bend with the input received through the steering wheel. If the vehicle starts to slide, it applies corrective braking to the appropriate wheel, or wheels, compensating for the slide and helping you regain control more rapidly.

ESP-plus offers additional safety in the form of two-way traction control, which helps prevent the driving wheels from spinning, under acceleration, on slippery surfaces.

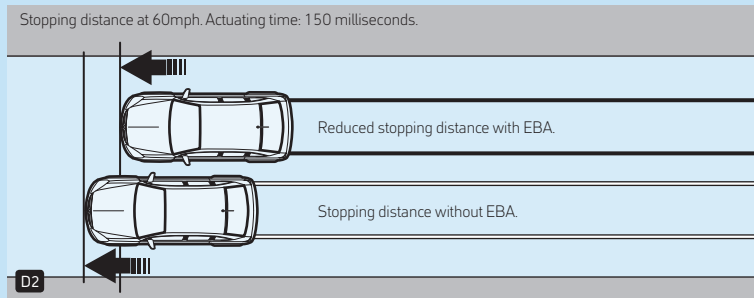

Emergency Brake Assist (EBA)

D2. Emergency brake assist detects the urgency with which the brake pedal is pressed and rapidly increases the pressure to the maximum the system can provide, shortening stopping distances. It also enhances pedal feel.

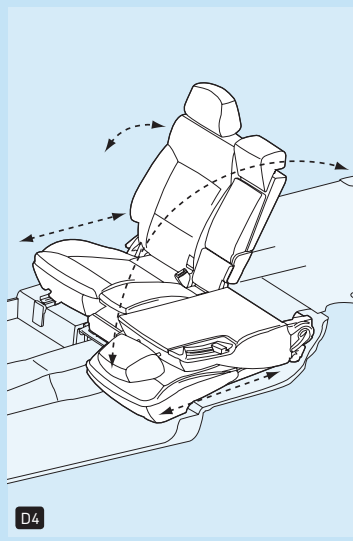

Signum FlexSpace® rear seating

D4. Signum's rear centre seat is ideal for that occasional fifth passenger. Alternatively you can swivel the padded section to reveal a useful storage console. There's even a pair of built-in drinks holders. Naturally, the seat comes with its own lap and diagonal inertia-reel seatbelt, cleverly concealed in the headlining.

The two individual rear seats are fully contoured, front seat-style, for optimum comfort and can be slid back and forth by up to 130mm to achieve the desired mix of legroom/luggage space. In addition, a recline facility for the two individual rear seats lets your passengers achieve their most comfortable travelling position.

The rear seat itself is split 40/20/40 to provide ample space for passengers and/or luggage. The seat cushions of the two individual outer rear seats slide forward as the backs fold in a simple, one-handed movement, creating a large flat load floor.

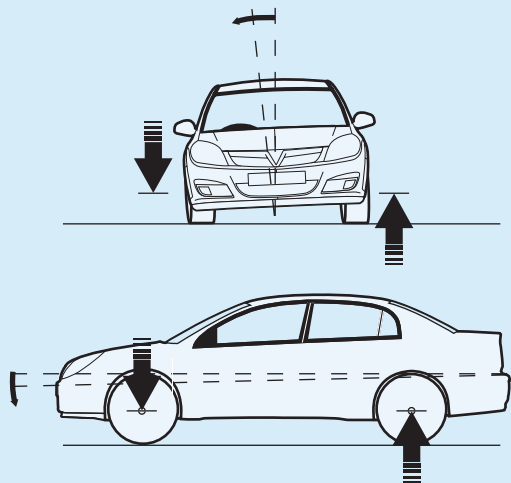

Interactive Driving System-plus (IDS-plus) with Continuous Damping Control (CDC)

D5. The Interactive Driving System (IDS-plus) chassis offers the driver an even more sporting driving experience, thanks mainly to the electronic control of the suspension. Pressing the Sport switch activates the CDC function – CDC monitors the roll, pitch and yaw of the car, and changes the rate of damping on each wheel to optimise the handling, effectively stiffening the suspension – but selectively. This means the vehicle will exhibit a reduced rate of roll and pitch, making it more responsive during direction changes and more settled during the braking/turn-in/acceleration transition when cornering. CDC is a major breakthrough in the segment.

Sport switch

D5. The functions of the Sport switch aren't limited to suspension control. When activated, it also affects the steering and accelerator pedal. The drive-by-wire throttle is altered electronically, leading to a sharper engine response and crisper acceleration, while the map of the power assisted steering is also adjusted, giving the driver a more positive initial turn-in on corner entry.

Adaptive Forward Lighting (AFL)

Adaptive Forward Lighting is a sophisticated new lighting system that allows drivers to see around corners and see further ahead at motorway speeds. This optional bi-xenon system employs two main functions:

Curving Light

D6. Controlled by a combination of steering wheel movement and sensors for the vehicle's speed and yaw angle, the Curving Light function allows the headlight beam to move up to 15 degrees left or right of the straight ahead position. This ensures the light is always following the trajectory plotted by the front wheels, rather than simply pointing straight ahead.

Cornering Light

D7. In order that junctions may be viewed more clearly before the turn has been made, Vauxhall has incorporated the Cornering Light function into the AFL system. An additional reflector, within the headlight unit, will broadly illuminate the roadside in the chosen direction of travel, depending on the vehicle's speed, steering angle and directional indicators.

Motorway Light

At speeds above 65mph, AFL raises the dipped headlight beam to extend the range of vision for increased safety at higher speed. The beam automatically returns to its normal position when the car falls below that speed.

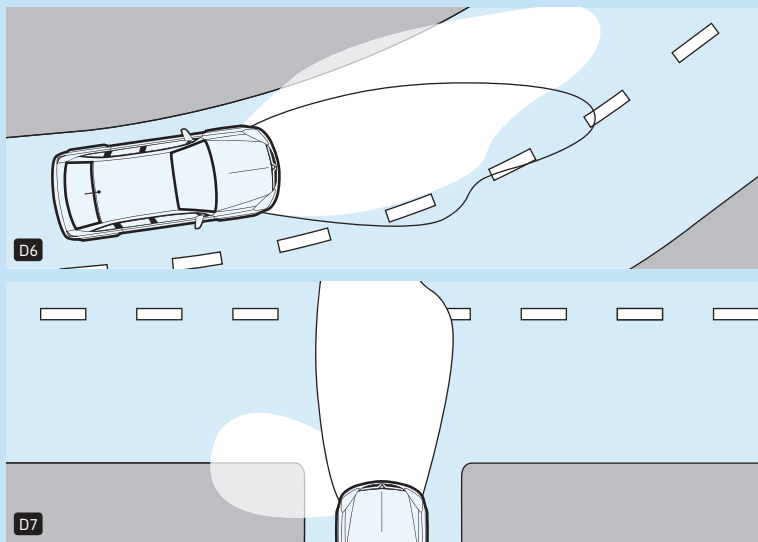

D5

D6

D7